

Remote Replication of SAP systems on the Hitachi Virtual Storage Platform

Implementation Guide

By Archana Kuppuswamy

April 2011



Feedback

Hitachi Data Systems welcomes your feedback. Please share your thoughts by sending an email message to SolutionLab@hds.com. Be sure to include the title of this white paper in your email message.

Table of Contents

Tested Solution Components	4
Hardware Components	5
Software Components.....	7
Solution Implementation	9
Configure the Storage Area Network	10
Configure Servers and the Operating Environment	12
Configure Storage	13
Install and Configure SAP Software.....	22
Prepare Storage Systems for Hitachi Universal Replicator Software	22
Configure Remote Replication Using CCI.....	27
Implement Remote Replication for SAP ERP Server	29
Appendix A: Database Parameter Files for Remote Replication of SAP System	32
Oracle Server Parameter File on the SAP ERP Server at Local Site	32
Oracle Server Parameter File on the SAP ERP Server at Remote Site	33
Appendix B: ShadowImage Configuration Files	36
ShadowImage Configuration Files for SAP ERP Server at Local Site.....	36
ShadowImage Configuration Files for SAP ERP Server at Remote Site.....	37

Remote Replication of SAP systems on the Hitachi Virtual Storage Platform

Implementation Guide

Most SAP customers rely on their IT environments to be available 24 hours a day, seven days a week. They cannot tolerate any process that might have a negative effect on the production instance's performance or availability. Given the critical nature of most SAP deployments, it is important to have a remote site with a copy of the data from the production instance. Replicating data to a remote secondary site represents the most effective insurance policy against catastrophic system failure. Remote data replication offers the fastest recovery time following an outage and the lowest risk of data loss, and it is therefore critical to SAP operations that have aggressive recovery time objectives (RTO) and recovery point objectives (RPO).

One of the most powerful capabilities of an advanced storage infrastructure is the ability to replicate data from the production instance at a local site to a secondary instance at the remote site. Although this capability is extremely powerful, it can be one of the most complex storage administration tasks. Introducing any process into a production SAP environment requires detailed planning and testing to ensure that the process does not impact production and that the process is documented and repeatable.

Hitachi takes a holistic approach to SAP environments, and the key to that approach is the Hitachi Virtual Storage Platform. The Hitachi Virtual Storage Platform is the industry's only 3D scaling storage platform. With the unique ability to concurrently scale up, scale out and scale deep in a single storage system, the Virtual Storage Platform is adaptable to varying performance, capacity, connectivity and virtualization requirements. No other enterprise storage platform can dynamically scale in three dimensions. Scaling up allows you to increase virtual server consolidation, improve utilization of resources, and reduce costs. Scaling out allows you to meet increasing demands by combining multiple chassis into a single logical system with shared resources. Scaling deep extends the advanced functions of the Virtual Storage Platform to external multivendor storage.

The advanced functionalities of the Hitachi Virtual Storage Platform fulfill the complex and demanding requirements of a SAP implementation where the data from the production instance must be replicated to a remote site. Although data replication can be performed at the server level, this function is more effectively performed within the storage infrastructure.

The solution described in this white paper uses two Hitachi Virtual Storage Platforms and Hitachi Universal Replicator software to replicate the data from a production SAP ERP instance at the local site and prepare the copy for access by a secondary server at the remote site in case the remote site is activated in the event of a disaster or a planned failover. It provides step-by-step instructions for preparing the environment for replication, configuring replication and implementing replication in an SAP environment.

This white paper is written for IT professionals who are charged with storage or SAP deployment or administration. It assumes basic knowledge of Storage Area Network concepts and operating practices. It provides prescriptive guidance that assists those individuals in configuring and managing the replication process in an SAP environment.

Tested Solution Components

This white paper describes a solution that includes SAP clients that access the SAP application infrastructure at the local site, which in turn stores data in and accesses data from a Hitachi Virtual Storage Platform storage system. These SAP clients can also access a SAP application infrastructure at a remote site, which in turn stores data and accesses data from the Hitachi Virtual Storage Platform family storage system at the remote site, as shown in Figure 1.

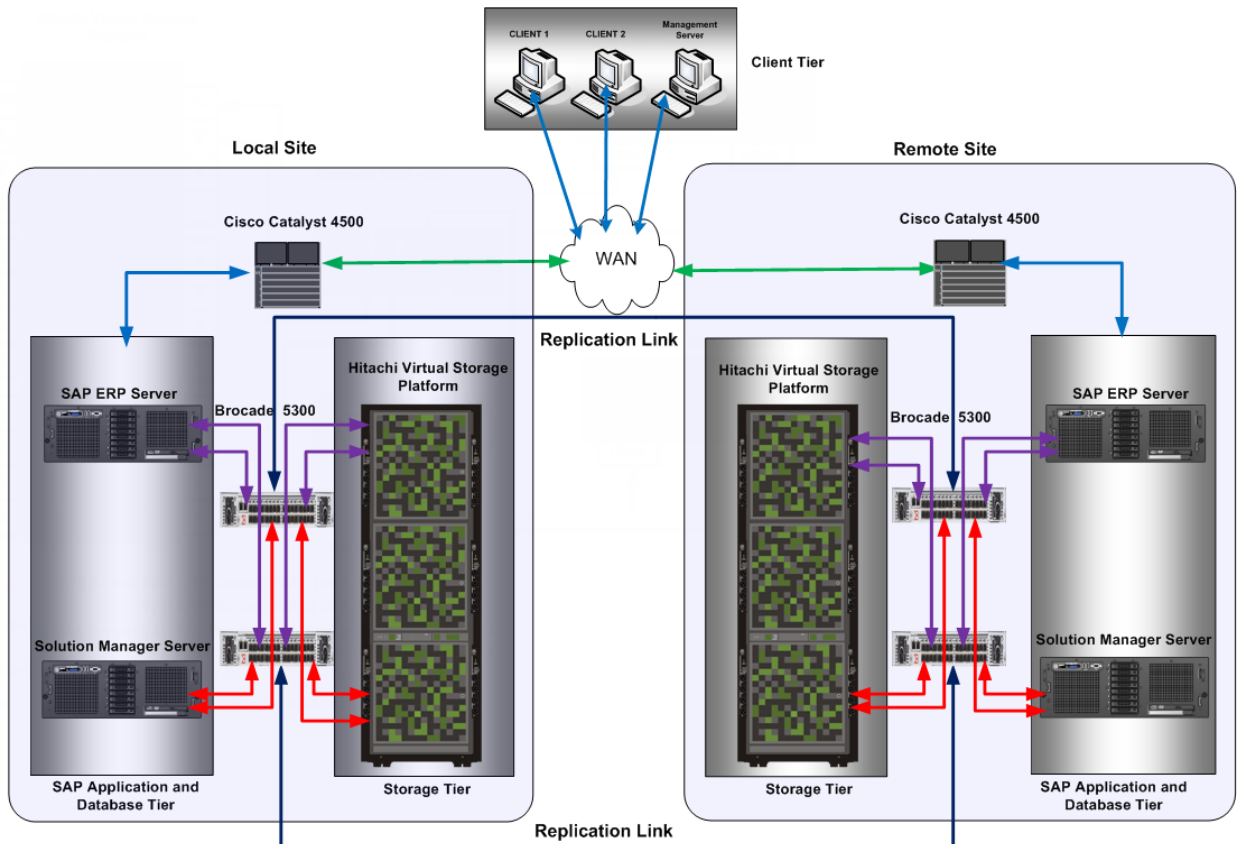

Figure 1

In the tested deployment, the SAP client tier consisted of Windows-based servers with the SAP GUI installed. The clients connected to the SAP system in the SAP application tier via a Cisco Catalyst 4500 switch at both the local and remote sites. Storage Navigator was installed on a Windows based management server in the client tier. The SAP ERP and the Solution Manager servers were installed on Linux servers in the SAP Application and Database tier at the local and remote sites. The SAP ERP and the Solution Manager systems were installed as a central system which means that both the SAP application and database were installed on a single server. The SAP application servers at either site were connected to the Hitachi Virtual Storage system via two Brocade 5300 switches.

The following sections describe the hardware and software components required to deploy the solution described in this white paper.

Hardware Components

Table 1 describes the hardware used to deploy this solution in the Hitachi Data Systems lab.

Table 1. Tested Deployment Hardware

<i>Hardware</i>	<i>Quantity</i>	<i>Configuration</i>	<i>Role</i>
Hitachi Virtual Storage Platform System	2	Firmware version 70-01-62-00/00 8 Fibre Channel ports used 2 pair of front-end directors 2 pair of back-end directors 64 x 300GB 10K RPM Fibre Channel drive 64GB cache;14GB shared memory	Primary Storage
Brocade 5300 SAN Fibre Channel switch	4	rev03 00.20.48.00 SAN switch with 8Gb/sec Fibre Channel ports	SAN switch
Server	1	6 Intel Xeon processors X5650 2.67GHz, 16GB memory 2 Emulex LPe11002-MH4 Fibre Channel host bus adapters (HBAs) 4Gb/sec	SAP Solution Manager server at local site
Server	1	6 Intel Xeon processors X5650 2.67GHz, 16GB memory 2 Emulex LPe11002-MH4 Fibre Channel host bus adapters (HBAs) 4Gb/sec	SAP ERP server at local site
Server	1	6 Intel Xeon processors X5650 2.67GHz, 16GB memory 2 Emulex LPe11002-MH4 Fibre Channel host bus adapters (HBAs) 4Gb/sec	SAP Solution Manager server at remote site
Server	1	6 Intel Xeon processors X5650 2.67GHz, 16GB memory 2 Emulex LPe11002-MH4 Fibre Channel host bus adapters (HBAs) 4Gb/sec	SAP ERP server at remote site
Server	2	Intel Pentium 3.0GHz processor 1GB memory	SAP clients
Server	1	Intel Pentium 3.0GHz processor 1GB memory	Management server with access to Hitachi Storage Navigator software

Hitachi Virtual Storage Platform

The Hitachi Virtual Storage Platform is the industry's only 3D scaling storage platform. With the unique ability to concurrently scale up, scale out and scale deep in a single storage system, the new Virtual Storage Platform flexibly adapts for performance, capacity, connectivity and virtualization. No other enterprise storage platform can dynamically scale in three dimensions. The Virtual Storage Platform provides virtual storage that meets the growing demands of server virtualization.

The trend in server virtualization is to consolidate the I/O workload of many servers onto a single storage system. As more virtual machines are consolidated onto a physical host, storage systems must be able to dynamically add more storage resources to keep up with I/O demand. The 3D scaling capability of the Virtual Storage Platform meets that requirement.

Scaling up allows you to increase virtual server consolidation, improve utilization of resources, and reduce costs. With the Hitachi Virtual Storage Platform, you can increase performance, capacity and connectivity by adding cache, processors, connections and disks to the base system. A virtual server that accesses the storage system can use all these resources, which act as one system managed as a common pool of resources.

Scaling out allows you to meet increasing demands by combining multiple chassis into a single logical system with shared resources. By scaling out you can support increased resource needs in virtualized server environments.

Scaling deep extends the advanced functions of the Hitachi Virtual Storage Platform to external multivendor storage. By dynamically virtualizing new and existing storage systems, those systems become part of the Virtual Storage Platform's pool of storage resources. Once virtualized, external data can then be migrated, tiered, replicated and managed by the Virtual Storage Platform. In this manner, older data storage systems can gain a longer useful life. You can extend distance replication for business continuity to lower-cost, lower-function storage systems by virtualizing them behind a Virtual Storage Platform.

The switch matrix architecture of the Virtual Storage Platform makes all of this possible. It connects the basic components, front-end directors, back-end directors, global cache modules and virtual storage directors. You can add redundant pairs of directors and cache modules as required without disruption to connected servers. All these resources are tightly coupled through a global cache that creates a common pool of storage resources. These resources can include external storage that is connected through front-end director initiator ports.

For more information about the Hitachi Virtual Storage Platform, see the Hitachi Data Systems [web site](#).

SAP Servers

Servers must meet specification requirements for the SAP Solution Manager and SAP ERP roles they are hosting. For more information about server requirements for SAP ERP, SAP Solution Manager and SAP clients, see the following SAP Notes, which are available to licensed customers from SAP's [web site](#):

- SAP Note 1094599, Installation NW7-SR3/Business Suite 2005 SR3 Unix/Oracle
- SAP Note 26147, SAP GUI Resources: Hardware and Software
- SAP Note 901070, Resource Requirements for SAPECC6

Software Components

Table 2 lists the software used to test this solution in the Hitachi Data Systems lab

Table 2. Tested Deployment Software

<i>Software</i>	<i>Version</i>
Hitachi Storage Navigator	Microcode dependent
Hitachi Command Control Interface (CCI)	01-24
Hitachi Universal Replicator	Licensed feature available with Hitachi Virtual Storage Platform
Hitachi Dynamic Provisioning Software	Licensed feature available with Hitachi Virtual Storage Platform
Hitachi Dynamic Link Manager Advanced	6.0.1.0.804
SAP ERP	6.0 Support Release 3 (SR3) with Enhancement Pack 4 IDES
SAP Solution Manager	7.0 Enhancement Package 1 on SP 25
SAP GUI	7.2
Oracle Database 10g Enterprise Edition	10.2.0.4

Hitachi Storage Navigator Software

Hitachi Storage Navigator software is the integrated interface for the Hitachi Virtual Storage Platform firmware and software features. Use it to take advantage of all of the Virtual Storage Platform's features. Storage Navigator software provides a Web-accessible graphical management interface.

Storage Navigator software is used to map security levels for SAN ports and virtual ports and for inter-system path mapping. It is used for logical unit (LDEV) creation and expansion, and for online volume migrations. It also configures and manages Hitachi Replication products. It enables online microcode updates and other system maintenance functions and contains tools for SNMP integration with enterprise management systems.

Hitachi Universal Replicator Software

Hitachi Universal Replicator software for the Hitachi Virtual Storage Platform is an advanced technology for asynchronously replicating data hosted on Virtual Storage Platform models. Asynchronous replication meets the challenge of maintaining a remote copy of SAP data without having a performance impact on the primary data. In asynchronous replication, an I/O update operation is considered complete when it is confirmed at the primary site. The Virtual Storage Platform manages the process of replicating the changes to the secondary site. The advantage of this strategy is that distance between sites does not affect the performance of the primary process.

Hitachi Universal Replicator software uses disk-based journaling and an optimized replication engine to reduce resource consumption and costs while increasing performance and operational resilience. The strengths of Hitachi Universal Replicator software are two key technical innovations: performance optimized, disk based journaling and a pull-style replication engine. Following are the key characteristics of the Universal Replicator software:

- **Replication across any distance without significant negative effect on host performance** - Hitachi Universal Replicator has been successfully used in replication configurations that span thousands of miles.
- **No acknowledgement dependencies from secondary site** - The Hitachi Universal Replicator mechanism allows replication to a remote site without the performance impact of waiting for each individual record to be acknowledged. Instead, Hitachi Universal Replicator manages the remote relationship at a controller level. If the communication to the remote unit is disrupted or the capability of the replication circuit is exceeded, Hitachi Universal Replicator retains a replicated write data in local journals and updates the write data when the condition is corrected.

There is a potential for some data lag between remote and primary sites, particularly at longer distances. The RPO is managed with the configuration of the data communication lines. When I/O activity at the primary site exceeds the capacity of the communication channel, the data is staged and moved to the secondary site in the same order as it was written at the primary site.

Hitachi Dynamic Provisioning Software

On the Hitachi Virtual Storage Platform, Hitachi Dynamic Provisioning software provides wide striping and thin provisioning functionalities. Hitachi Dynamic Provisioning software provides for one or more pools of storage across many RAID groups within a Virtual Storage Platform. One or more Dynamic Provisioning virtual volumes (DP-VOLs) of a user-specified logical size of up to 60TB (with no initial physical space allocated) are created against each pool.

Hitachi Dynamic Provisioning software provides features that provide virtual storage capacity to eliminate application service interruptions, reduce costs, and simplify administration, as follows:

- Optimizes or “right-sizes” storage performance and capacity based on business or application requirements.
- Supports deferring storage capacity upgrades to align with actual business usage.
- Simplifies and adds agility to the storage administration process.
- Improves performance

Hitachi Dynamic Link Manager Advanced Software

Hitachi Dynamic Link Manager Advanced software bundles Hitachi Dynamic Link Manager I/O multipathing software and Hitachi Global Link Manager software. Hitachi Dynamic Link Manager software, which is installed on the SAP ERP and SAP Solution Manager servers, includes capabilities such as path failover and failback and automatic load balancing to provide higher data availability and accessibility.

In this solution Hitachi Dynamic Link Manager Advanced software is installed on the SAP ERP server and the SAP Solution Manager server at both the local and remote sites.

SAP Software

SAP ERP combines scalable and effective software for enterprise resource planning (ERP) with a flexible, open technology platform that can leverage and integrate SAP and non-SAP systems. SAP provides end-to-end software functionality for enterprise management.

SAP Solution Manager is a service and support platform that provides the integrated content, tools and methodologies to implement, support and monitor operations of an SAP implementation. Solution Manager is installed on a separate system. Hitachi Data Systems uses the Solution Manager server for these functions:

- Configuring installation keys for the install of any SAP ABAP and Java instance
- Approving the download of any updates from SAP, like service packs or enhancement packs
- Installing SAP enhancement packs onto ABAP instances
- Obtaining support from SAP

SAP GUI is the client software that allows SAP users to access various functionalities in SAP applications and SAP Solution Manager.

SAP systems can be used with a variety of databases available from different vendors. In this solution the ERP and Solution Manager systems at the local and remote sites use Oracle databases. Oracle has several technological features embedded in the database software that provide flexibility and manageability. Some of these features cover backup and recovery, cloning of databases and so on.

Solution Implementation

Deploying this solution requires following these high-level steps:

1. Configure the Storage Area Network at local and remote site
2. Configure servers and the operating environment.
3. Configure storage.
4. Install and configure SAP software.
5. Prepare the storage system for Hitachi Universal Replicator software.
6. Configure replication using CCI.
7. Implement remote replication.

Your checklist might vary based on your environment. More details about each of these steps are included in the following sections.

Configure the Storage Area Network

At the local site the SAP ERP server and SAP Solution Manager server use multiple HBAs per server to support redundancy. When deploying an SAP system, the storage used by SAP Solution Manager server and SAP ERP server must be isolated from each other in a SAN. As shown in Figure 2, four separate Fibre Channel zones are created, one for each HBA of the SAP Solution Manager server, and SAP ERP server. The Fibre Channel zones for the SAP Solution Manager and SAP ERP server do not share Fibre Channel ports on the storage system. World wide names (WWNs) of the HBAs residing on a physical server can be assigned to a host group and then a logical device (LDEV) can be associated with each host group. This means that a group of LDEVs can be isolated to be used by only the assigned physical servers.

The SAP ERP server and the Solution Manager server are connected via two HBAs in each server to two Brocade 5300 switches. The Brocade 5300 switches, in turn, are connected to four different ports of the Hitachi Virtual Storage Platform. The remote site's Storage Area Network has the same configuration as the local site.

This solution uses two initiator ports on the storage system at the local site connected to two target ports on the storage system at the remote site. It also uses two initiator ports from the storage system at the remote site connected to two target ports on the storage system at the local site.

The Hitachi Virtual Storage Platform supports active-active multipath connectivity. To obtain maximum availability, design and implement your host-storage connections so that at least two unique paths exist from the host to the storage system. Hitachi Data Systems recommends the use of dual SAN fabrics, multiple HBAs and host-based multipathing software when deploying SAP systems. For this solution Hitachi Dynamic Link Manager was used for the multipathing software.

The choice of load-balancing algorithm depends on the specific environment and access patterns of the application. In most cases, the extended round robin algorithm provides the best overall performance. In some environments, such as an environment shared with other applications, one of the other algorithms might give the best overall performance.

Figure 2 illustrates the zones used for the local site. It also illustrates the redundant paths that are managed by Hitachi Dynamic Link Manager Advanced software in the deployment tested for this solution at the local site.

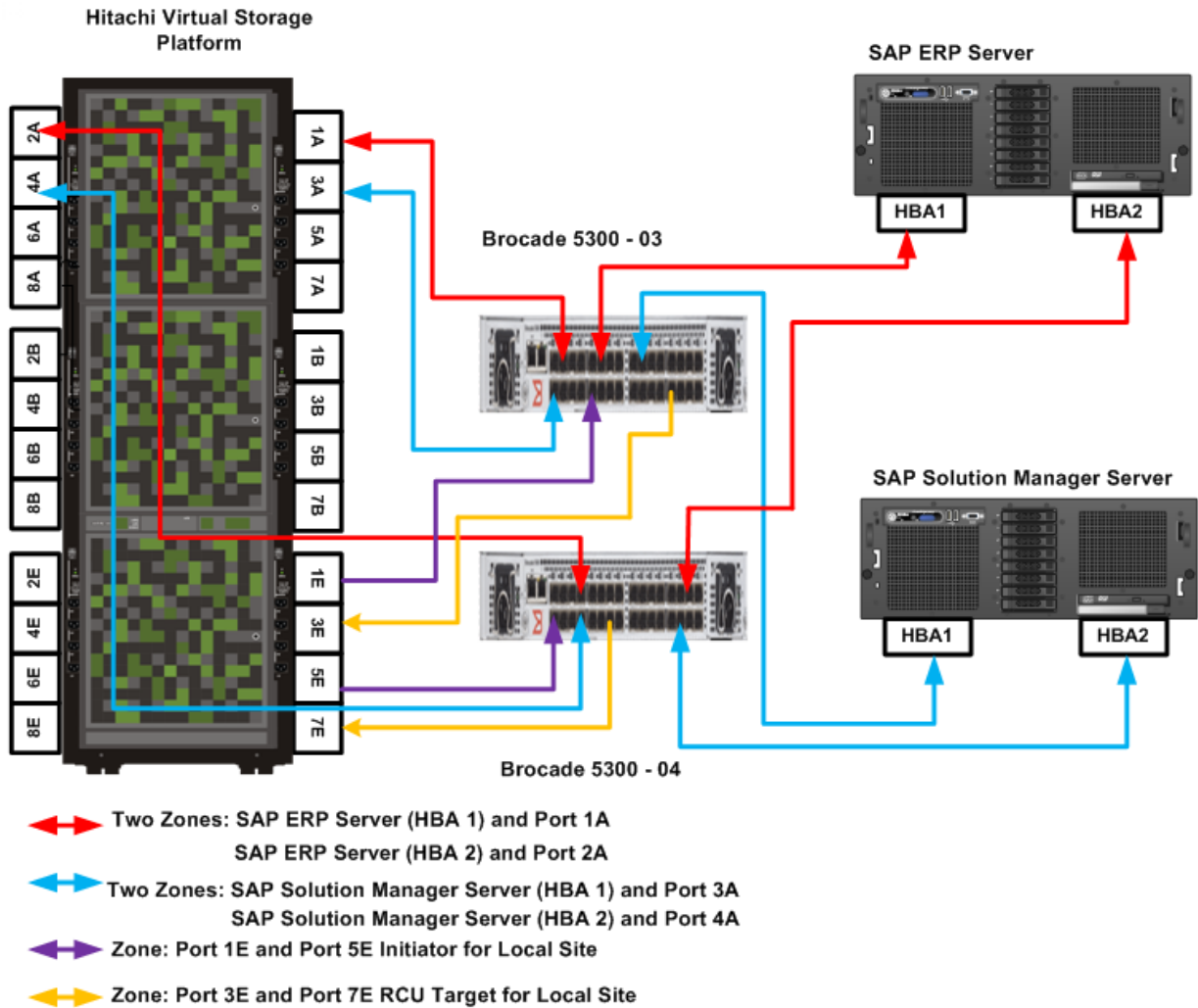

Figure 2

Figure 3 illustrates the zones used at the remote site. It also illustrates the redundant paths that are managed by Hitachi Dynamic Link Manager Advanced software in the deployment tested for this solution at the remote site.

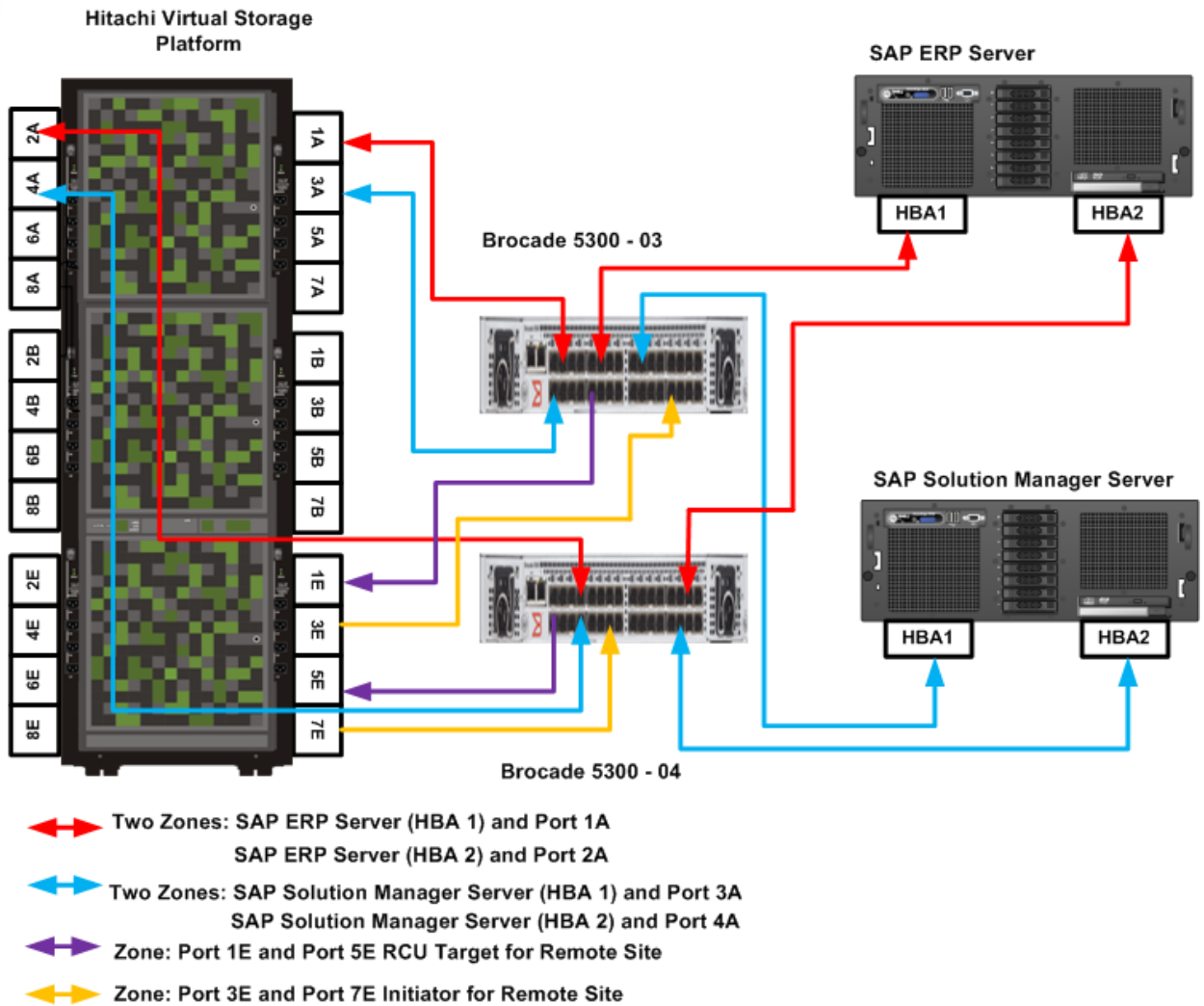

Figure 3

Configure Servers and the Operating Environment

Configure SAP Solution Manager and SAP ERP server at both local and remote site according to their specific installation guides. These guides are available to licensed SAP customers at <http://service.sap.com/instguides>. Deploy the SAP ERP server at the remote site by following the same guidelines as used for the SAP ERP server at the local site. Hitachi Data Systems recommends deploying the SAP ERP server on the remote site with the same configuration as the SAP ERP server on the local site. This solution requires that the user number (UID) and the group number (GID) for the SAP software owner and Oracle users are the same on the SAP ERP server at the local and remote site

When deploying SAP Solution Manager and SAP ERP server for this solution at local and remote site, Hitachi Data Systems used four servers each with 6 CPUs and 16 GB memory. Each server has two Emulex LPe11002-MH4 8Gb/s Fibre Channel host bus adapters (HBAs) and two 1GB network interface cards. Two SAP client servers and one management server for access to Hitachi Storage Navigator software were deployed using servers with two CPUs and 1GB memory.

Hitachi Data Systems installed Red Hat Enterprise Linux version 5.2 (x86 64 bit) on the SAP Solution Manager and SAP ERP server. Microsoft Windows 2008 was installed on SAP clients and the management server.

For more information about supported operating systems, see the following SAP Notes, which are available to licensed customers from SAP's [web site](#):

- SAP Note 171356, *SAP Software on Linux: Essential*
- SAP Note 1048303, *Red Hat Enterprise Linux 5.x: Installation and Upgrade*
- SAP Note 1172419, *Linux: Supported Java Versions on the x86_64 Platform*

Complete SAP Pre-installation Tasks

You must complete several pre-installation tasks before installing either SAP Solution Manager or SAP ERP software or configuring your storage. For more information about pre-installation tasks, see the following SAP Notes, which are available to licensed customers from SAP's [web site](#):

- SAP Note 855498, *Installation Pre-requisite Checker, SAP Guides*
- SAP Note 1145779, *SAP Solution Manager 7 Installation*
- SAP Note 1052298, *SAP NetWeaver 7.0(2004s) SR3 Installation on UNIX/Oracle*
- SAP Note 830576, *Parameter Recommendations for Oracle 10g*
- SAP Note 1289199, *Information about Oracle Parameters*
- SAP Note 828268, *Oracle Database 10g: New Functions*
- SAP Note 871735, *Current Patch Set for Oracle 10.2.0*

Hitachi Data Systems recommends using a logical volume manager (LVM) to create volume groups and logical volumes. For this solution, the logical volumes, volume groups and file systems are laid out based on the application needs. The SAP Solution Manager server and the SAP ERP server at local and remote site use similar volume group, logical volume and file system configuration.

Configure Storage

The following sections describe how to configure your storage for this solution. For this solution, Hitachi Data Systems used Hitachi Dynamic Provisioning software to provision storage for the databases. Use Hitachi Storage Navigator software to create and manage the storage objects.

Standard LDEVs were used for the logs, which includes online redo logs, mirrored logs and the archived logs for all of the SAP servers. Dynamic Provisioning volumes (DP-VOLs) were used for all the other logical volumes for the servers.

To ensure that the failure of a disk that contains a data file does not also cause the loss of the redo logs needed to recover the data file, in this solution we store the online redo logs, mirrored logs and archived log files on a disk separate from that of the data files.

At the local site two Dynamic Provisioning pools were created for the SAP databases, one for each SAP server. All RAID groups used to create the Dynamic Provisioning pools were configured as RAID-5 (3D+1P). All drives were 300GB 10K RPM SAS drives. A total of four RAID groups were used for each of the Dynamic Provisioning pools, giving each pool a storage capacity of 3.14TB. Nine DP-VOLs were configured per Dynamic Provisioning pool. The same configuration was used at the remote site.

Table 3 lists the Dynamic Provisioning pools created for SAP Solution Manager and SAP ERP server at the local and remote sites.

Table 3. Hitachi Dynamic Provisioning Pools at Local and Remote site

<i>Dynamic Provisioning Pool</i>	<i>Role</i>
SAP_SOL	SAP Solution Manager server
SAP_ERP	SAP ERP server

Table 4 lists storage configuration details for LDEVs created for the SAP Solution Manager server in the SAP_SOL pool at the local and remote sites. All LDEVs were mapped to storage ports 3A and 4A.

Table 4. LDEV Storage Configuration for the SAP Solution Manager Server

<i>LDEV</i>	<i>Host LUN</i>	<i>Size (GB)</i>
00:02:00	00	50
00:02:01	01	50
00:02:02	02	50
00:02:03	03	50
00:02:09	09	200
00:02:0A	0A	200
00:02:0B	0B	200
00:02:0C	0C	200
00:02:0D	0D	200

Table 5 lists storage configuration details for LDEVs created for the SAP ERP server in the SAP_ERP pool at the local and remote site. All LDEVs were mapped to storage ports 1A and 2A.

Table 5. LDEV Storage Configuration for the SAP ERP Server

<i>LDEV</i>	<i>Host LUN</i>	<i>Size (GB)</i>
00:03:00	00	50
00:03:01	01	50
00:03:02	02	50
00:03:03	03	50
00:03:09	09	200
00:03:0A	0A	200
00:03:0B	0B	200
00:03:0C	0C	200
00:03:0D	0D	200
00:03:0E	0E	1

In the Hitachi Data Systems lab environment one RAID-5 (3D+1P) group (RAID group 1-1) was used to store the SAP logs. This includes online redo logs, mirrored logs and the archived logs for the SAP servers. In a production environment the online redo logs and mirrored logs should be stored on separate spindles to protect against loss of data. All drives were 300GB 10K RPM SAS drives. The RAID group had a storage capacity of 900GB. 10 LDEVs were created in this RAID group. The same configuration was used at the remote site.

Table 6 lists the LUN configuration of RAID group 1-1 for the logs of SAP Solution Manager server and SAP ERP server.

Table 6. LDEV Configuration of RAID Group 1-1 for SAP ERP and Solution Manager Server Logs

<i>LDEV</i>	<i>Host Group</i>	<i>Host LUN</i>	<i>Size (GB)</i>	<i>Server</i>
00:02:04	1	04	10	SAP Solution Manager
00:02:05	1	05	10	SAP Solution Manager
00:02:06	1	06	10	SAP Solution Manager
00:02:07	1	07	10	SAP Solution Manager
00:02:08	1	08	150	SAP Solution Manager
00:03:04	2	04	10	SAP ERP
00:03:05	2	05	10	SAP ERP
00:03:06	2	06	10	SAP ERP
00:03:07	2	07	10	SAP ERP
00:03:08	2	08	150	SAP ERP

Table 7 lists details for disk group, logical volume and file system layout of the SAP Solution Manager server and the SAP ERP server at local and remote site. All four servers have the same layout.

Table 7. Storage Configuration Details for SAP Solution Manager Server and SAP ERP Server

<i>Host LUN</i>	<i>Disk Group</i>	<i>Logical Volume</i>	<i>File System Mount Point</i>	<i>Usage</i>
00	appbin_vg	appbin_sapmnt_lv	/sapmnt	File system for central repository, SAP binaries, and central location for moving data to another system when required
01	appbin_vg	appbin_usrsap<SID>_lv	/usr/sap/<SID>	File system for SAP binaries
02	appbin_vg	appbin_usrsap_trans_lv	/usr/sap/trans	File system for central location for moving data to another system
03	appbin_vg	appbin_oracle_lv	/oracle	File system for Oracle binaries for installation of Oracle, Oracle client, home directory for Oracle user, and to store data temporarily for online data re-organization respectively
04	applog_vg	applogA_lv	/oracle/<SID>/origlogA	File system for online redo logs of the database
05	applog_vg	appmirrlogB_lv	/oracle/<SID>/mirrlogB	File system for duplex logs of the database
06	applog_vg	applogB_lv	/oracle/<SID>/origlogB	File system for online redo logs of the database
07	applog_vg	appmirrlogA_lv	/oracle/<SID>/mirrlogA	File system for duplex logs of the database
08	appalog_vg	apparch_lv	/oracle/<SID>/saparch	File system for archived logs
09	appdata_vg	appdata_sapdata1_lv	/oracle/<SID>/sapdata1	File system for SAP data in oracle database
0A	appdata_vg	appdata_sapdata2_lv	/oracle/<SID>/sapdata2	File system for SAP data in oracle database
0B	appdata_vg	appdata_sapdat3_lv	/oracle/<SID>/sapdata3	File system for SAP data in oracle database
0C	appdata_vg	appdata_sapdata4_lv	/oracle/<SID>/sapdata4	File system for SAP data in oracle database
0D	appdata_vg	appdata_oradata_lv	/oracle/<SID>/oradata	File system for Oracle data dictionary, temporary, UNDO, and users tablespace data

The following sections describe in detail how to configure your storage for this solution.

Create Dynamic Provisioning Pools

This procedure assumes that zoning within your Fiber Channel fabric is complete. To create Dynamic Provisioning pools on a Hitachi Virtual Storage Platform using Hitachi Storage Navigator software, follow these steps:

1. Choose **Actions > Pool > Create Pools**.

The **Create Pools** window displays.

2. From the **Pool Type** drop-down menu, choose **Dynamic Provisioning**.
3. Click the **Select Pool VOLs** button.

The **Select Pool VOLs** window displays.

4. Highlight one or more pool volumes in the **Available Pool Volumes** pane and click **OK**.

The **Create Pools** window displays with **Total Selected Pool Volume** and **Total Selected Capacity** fields populated.

5. Assign a prefix for the pool name in the **Prefix** field.
6. (Optional) Assign an initial number for the pool name in the **Initial Number** field.
7. Expand the **Options** pane.
8. Assign a pool ID in the **Pool ID** field.
9. Assign a subscription limit in the **Subscription Limit** field.

This is the percentage of oversubscription for this pool that you allow in your environment.

10. Choose a value from the **User-Defined Threshold** drop-down menu and click the **Add** button

The **User Defined Threshold** value determines when a pool capacity alert is triggered.

The **Selected Pools** pane is populated.

11. Click the **Finish** button.
12. The **Create Pools** window displays.
13. Click the **Apply** button.

Create LDEVs within a Dynamic Provisioning Pool

This procedure assumes that Dynamic Pool creation in your environment is complete. To create the LDEVs used by the datafiles within a Dynamic Provisioning pool using Hitachi Storage Navigator software, follow these steps:

1. Choose **Actions > Logical Device > Create LDEVs**.

The **Create LDEVs** window displays.

2. From the **Provisioning Type** drop-down menu, select **Dynamic Provisioning**.
3. From the **Emulation Type** drop down menu, select **OPEN-V**.
4. (Optional) Choose a menu item from the **Drive Type/RPM** drop-down menu and from the **RAID Level** drop-down menu.

These options allow you to filter the available pool volumes.

5. Click the **Select Pool** button.

The **Select Pool** window displays.

6. Highlight a pool in the **Available Pools** pane and click **OK**.

The **Create LDEVs** window displays with the **Selected Pool Name** and the **Selected Pool Capacity** fields populated.

7. Enter a capacity amount in the **LDEV Capacity** field and choose a unit of measure from the drop-down menu.
8. Enter the number of LDEVs of that size to be created in the **Number of LDEVs** field.
9. In the **LDEV Name** pane, assign a prefix in the **Prefix** field and assign an initial number in the **Initial Number** field.
10. Expand the **Options** pane.
11. Review the value in the **LDKC** field.

Modify the LDKC value if the default of **00** is not appropriate. This is most often the case if the storage will be configured with more than one LDKC.

12. Choose a value from the **CU** drop-down menu.
13. Choose a value from the **DEV** drop-down menu.
14. (Optional) Choose a value from **Interval** drop-down menu.

Leave this value at the default of **0** for sequential numbering of LDEVs. If you want a different numbering sequence, choose a different value.

15. Review the default values in the **Initial SSID** field, the **CLPR** field and **Processor Blade** field.

In most situations, use the default values. Change them only if your environment requires different values.

16. Click the **Add** button.

The **Selected LDEVs** pane is populated.

17. Click the **Finish** button.

The Create **LDEVs** window displays.

18. Click the **Apply** button.

Create LDEVs in a RAID Group

This procedure is used to create the LDEVs used by the various SAP logs. To create one or more LDEVs in a RAID group using Hitachi Storage Navigator software, follow these steps:

1. Choose **Actions > Create LDEVs**

The **Create LDEVs** window displays.

2. From the **Provisioning Type** drop-down menu, select **Basic**.
3. From the **Emulation Type** drop down menu, select **OPEN-V**.
4. (Optional) Choose a menu item from the **Drive Type/RPM** drop-down menu and from the **RAID Level** drop-down menu.

These options allow you to filter the available RAID group volumes.

5. Choose the **Select Free Spaces**

The Available Free Spaces window displays

6. Highlight the **Parity Group** in the **Available Free Space** window and choose **OK**
7. Enter a capacity amount in the **LDEV Capacity** field and choose a unit of measure from the drop-down menu.
8. Enter the number of LDEVs of that size to be created in the **Number of LDEVs** field.
9. In the **LDEV Name** pane, assign a prefix in the **Prefix** field and assign an initial number in the **Initial Number** field.
10. Expand the **Options** pane.
11. Review the value in the **LDKC** field.

Modify the LDKC value if the default of **00** is not appropriate. This is most often the case if the storage will be configured with more than one LDKC.

12. Choose a value from the **CU** drop-down menu.
13. Choose a value from the **DEV** drop-down menu.
14. (Optional) Choose a value from **Interval** drop-down menu.

Leave this value at the default of **0** for sequential numbering of LDEVs. If you want a different numbering sequence, choose a different value.

15. Review the default values in the **Initial SSID** field, the **CLPR** field and **Processor Blade** field.

In most situations, use the default values. Change them only if your environment requires different values.

16. Click the **Add** button.

The **Selected LDEVs** pane is populated.

17. Click the **Finish** button.

The **confirm** window for creating LDEVs displays.

18. Click the **Apply** button.

Create Host Groups

To create host groups using Storage Navigator software, follow these steps:

1. Choose **Actions > Ports/Host Groups > Create Host Groups**.

The Create Host Groups window displays.

2. Assign a name in the **Host Group Name** field.
3. From the **Host Mode** drop-down menu, choose **00[Standard]**.
4. In the **Available Hosts** pane, highlight one or more hosts.
5. In the **Available Ports** pane, highlight one or more ports.
6. Click the **Add** button.

The **Selected Host Groups** pane is populated.

7. Click the **Finish** button.

The **Create Host Groups** window displays.

8. Click the **Apply** button.

Map LDEVs

To map LDEVs using Hitachi Storage Navigator software, follow these steps:

1. Choose **Actions > Logical Device > Add LUN Paths**.

The **Add LUN Paths** window displays.

2. In the **Available LDEVs** pane, highlight one or more LDEVs.
3. Click the **Add** button.

The **Selected LDEVs** pane is populated.

4. Click **Next**.

The **Add LUN Paths** window displays.

5. In the **Available Host Groups** pane, highlight one or more host groups.
6. Click the **Add** button.

The **Selected Host Groups** pane is populated.

7. Click **Next**.

The **Add LUN Paths** window displays.

8. Click **Finish**.

The **Add LUN Paths** window displays.

9. Click the **Apply** button.

Install and Configure Hitachi Dynamic Link Manager Advanced Software

Follow these steps to install Hitachi Dynamic Link Manager Advanced software and to create LVM objects and file systems on the disks on the ERP and Solutions Manager servers:

1. Execute the following command on the server on which you want to install Hitachi Dynamic Link Manager Advanced software:

```
./installhdlm
```

When the installation is complete, Hitachi Dynamic Link Manager Advanced software displays a message indicating that the software was successfully installed.

Hitachi Dynamic Link Manager Advanced software names your disk device using the following format:

```
sddl m<di sk- devi ce>
```

<di sk- devi ce> is a combination of letters from a to z identifying your disk device.

2. On each server, using LVM, create a physical volume (PV) on each disk device using the following syntax:

```
pvcreate /dev/sddl m<di sk- devi ce>
```

3. On each server, using LVM, create volume groups using the following syntax:

```
vgcreate -s 64 <vol ume group name> <physi cal vol ume name(s)>
```

Table 7 show the volume groups needed for this solution.

4. On each server, create logical volumes, using the following syntax:

```
lvcreate -l <si ze of logi cal vol ume> -n <vol ume vol ume name> <vol ume group name>
```

Table 7 show the logical volumes and respective volume groups needed for this solution.

5. On each server, create a file system for each logical volume using the following syntax:

```
mke2fs -t ext2 /dev/<volume group name>/<logical volume name>
```

6. Mount each file system using the following syntax:

```
mount -t ext2 -o async /dev/<volume group name>/<logical volume name>  
/<mount point>
```

Table 7 show the file systems and mount points needed for this solution.

Install and Configure SAP Software

Use your existing or new Solution Manager instance to deploy the SAP ERP software for the servers at the local and remote sites. Install SAP Solution Manager and SAP ERP software on dedicated servers. The SAP GUI software is installed on SAP clients.

It is important to verify that the newly installed and configured hardware and software are operating properly before you make your deployment live. The verification process involves logging in to each server and executing a few transactions. For more information, see SAP Notes, which are available to licensed customers from SAP's [web site](#).

Prepare Storage Systems for Hitachi Universal Replicator Software

Hitachi Universal Replicator Software Functionality

Hitachi Universal Replicator software is a disaster recovery solution for protecting large amounts of data that span multiple volumes. Hitachi Universal Replicator software uses group-based, update sequence consistency to enable fast and accurate recovery.

Hitachi Universal Replicator software creates duplicate volumes by copying data from the primary data volumes (P-VOL) in the storage system or main control unit (MCU) at the local site to the secondary data volumes (S-VOL) in the storage system or remote control unit (RCU) at the remote location. Hitachi Universal Replicator software also makes sure that any updates on the primary data volumes are applied to the secondary data volumes. Hitachi Universal Replicator software performs the following operations to copy data from the primary data volumes to the secondary data volumes and maintain replication:

- **Base journal copy** - Also known as the initial copy, this operation synchronizes the data in the P-VOL and the S-VOL. This operation is independent from host I/O and is performed when a data volume pair is created or a suspended pair is resynchronized.
- **Journal obtain** - Stores the write data as a journal data in the primary journal volume (M-JNL) in the MCU with every update of the P-VOL according to the write instructions from the host. The host assigns write-sequence numbers to the data sent to the master journal volume. Write-sequence numbers and the metadata attached to the journal data insure consistency with the data in the P-VOL.

- **Journal copy** - Copies data in the M-JNL in the MCU to the secondary journal volume (R-JNL) at the remote site. During the journal copy operation, data is pulled from the MCU journal cache (data might be read from the M-JNL if the data was destaged to the M-JNL) to the RCU journal cache and then to the R-JNL. The RCU issues a read journal command to the MCU to request the transfer of the journal data that is stored in the primary journal volumes after the pair create or pair resync operation from the MCU. After the journal copy operation is complete, the MCU discards the journal data.
- **Journal restore** - Writes data from the R-JNL to the S-VOLs volumes by maintaining the write order fidelity. After the data in the R-JNL is written to the S-VOL, the RCU discards the journal data.

Figure 4 describes Universal Replicator software operations.

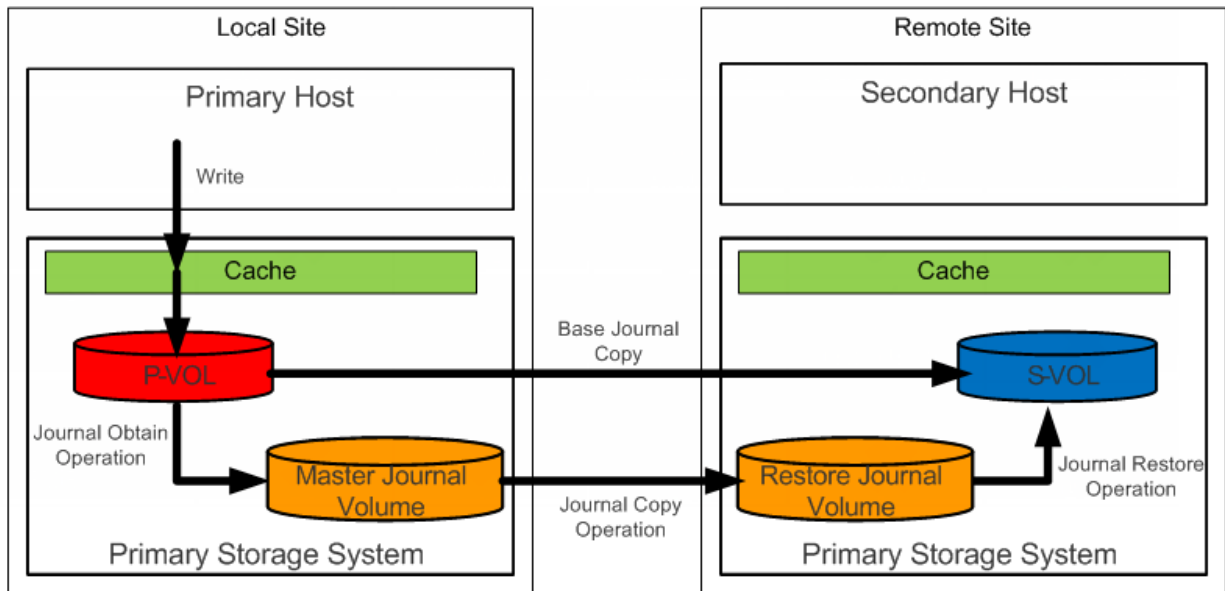

Figure 4

To determine the required number of initiator and RCU target ports on a Hitachi Virtual Storage Platform refer to the "*Hitachi Universal Replicator User Guide*" for the Hitachi Virtual Storage Platform. To enable Hitachi Universal Replicator software on your storage systems follow these high-level steps on both the MCU and RCU storage systems using Hitachi Storage Navigator software:

1. Install Hitachi Command Control Interface.
2. Create command devices.
3. Configure port attributes.
4. Add a disk controller (DKC) definition.
5. Create journal groups.

Install Hitachi Command Control Interface

To install Hitachi Command Control Interface (CCI) software on the SAP ERP server at both local and remote site, follow these steps:

1. Insert the installation media.
2. Navigate to the root directory:

```
# cd /
```
3. Copy all files from the installation media using the following command:

```
# cpio -i dmuf < /mnt/cdrom/LINUX/HORCM
```
4. Execute the HORCM installation command:

```
# /HORCM/horcminstall.sh
```

Creating a Command Device

Create command devices at the local and remote sites and ensure that all the command devices are accessible through multiple I/O paths.

1. Create an LDEV in the Hitachi Dynamic Provisioning pool created for SAP ERP server as described in the *Create LDEVs within a Dynamic Provisioning Pool* section earlier in this paper and associate it to a host group of the host connection using Hitachi Storage Navigator software.

This solution uses 1GB LDEVs for the command device.

2. Convert an LDEV to a command device in Storage Navigator software by following these steps:
 - a. Choose **Actions > Ports/Host Groups**.
 - b. Expand the port (for example Port CL3-A) and choose the **Host group** to which the LDEV for command device has been mapped.
 - c. On the right pane, choose the **LUNs** and select the LDEV to be converted to command device.
 - d. Select the option **Edit Command Device** at the right bottom of the screen.
The **Edit Command Devices** window displays.
 - e. In the **Edit Command Devices** pane, select the **enable** radio button.
 - f. Click **Finish**.
 - g. Click the **Apply** button.

Configuring Port Attributes

You must have at least one initiator and one RCU target. This solution uses two initiators and two RCU targets.

To configure port attributes of the MCU and RCU storage systems using Storage Navigator software, follow these steps:

1. On the MCU storage system Choose GO > Universal Replicator > DKC Operation.

The **Universal Replicator DKC Operation** window displays.

2. Select the **Port** radio button.

A **Subsystem** navigation tree displays in the left pane.

3. Select a channel adapter (for example, **CHA-1H**) from the list of channel adapters

A list of port pairs displays in the right pane.

4. In the right pane, right-click the port pair (for example **1E, 5E**) to be converted to an initiator and select **Initiator** from the drop-down menu.

The port changes to an initiator.

5. Click the **Apply** button.

A **Do you want to apply?** prompt displays in a pop-up window.

6. Click the **OK** button.

An **Are you sure you want to exchange the specified ports? Please confirm the associated channel paths are off-line** prompt displays in a pop-up window.

7. Click the **OK** button.

An **Exchange the channel cable connections after confirmation of the port type** prompt displays in a pop-up window.

8. Click the **OK** button.

9. **The requested operation is complete** prompt displays in a pop-up window

Click the **OK** button.

10. Repeat Step 3 through Step 9 to convert additional targets to initiators.

11. Repeat Step 3 through Step 9 to convert a target to an RCU target.

Note: When converting targets to RCU targets, select RCU Target from the drop-down menu in Step 4.

12. Repeat Step 1 through Step 11 to configure ports on the RCU storage system.

Adding a DKC Definition

To add a DKC definition on the MCU and RCU storage systems, follow these steps using Storage Navigator software:

1. On the MCU storage system, choose **GO > Universal Replicator > DKC Operation**.
The **Universal Replicator DKC Operation** window displays.
2. Select the **DKC** radio button.
A LDKC navigation tree displays in the left pane.
3. Select a LDKC (for example, **LDKC#00**) from the navigation tree.
4. Right-click in blank space on the left pane.
A drop-down menu displays.
5. Select **DKC Operation > Add DKC** from the drop-down menu.
The **ADD DKC** dialog box displays.
6. Provide the following information in the **ADD DKC** dialog box:
 - a. Enter the serial number for the remote storage system in the **S/N** field.
 - b. Choose the LDKC of the remote storage system from the **LDKC** drop-down menu.
 - c. Choose **6 (VSP)** from the **Controller ID** drop-down menu.
 - d. Choose the local storage system port and its corresponding pair-port in **M-R path** pane.
 - e. Click the **Option** button.
The **DKC Option** dialog box displays.
 - f. Enter values in the **Minimum Paths** and **RIO MIH Times (sec)** fields.
 - g. Click the **Set** button.
The **DKC Option** dialog box closes
7. Click the **Apply** button.
A **Do you want to apply?** prompt displays in the pop-up window.
8. Click the **OK** button.
The **requested operation is complete** prompt displays in a pop-up window
9. Click the **OK** button.
10. Repeat Steps 1 through 9 on the RCU storage system to add a DKC on the RCU.

Creating Journal Groups

To create journal groups using Storage Navigator software, follow these steps:

1. On the MCU System, choose **GO > Universal Replicator > Journal Operation**.

The **Universal Replicator Journal Operation** dialog box displays.

2. In the **Journal Groups** navigation tree, expand the **Free** item.

3. Highlight a free journal group from the list.

Details of the selected free journal group display in the right pane.

4. Right-click the highlighted journal group in the right pane and choose **Edit JNL Volumes** from the drop-down menu.

The **Edit JNL Volumes** dialog box displays.

5. Select the **CU** radio button.

6. From the drop-down menu to the right of the **CU** radio button, select a CU.

The **Free Volume** pane populates.

7. Select a volume or volumes from the **Free Volume** pane.

The **Add** button activates.

8. Click the **Add** button.

The **JNL Volumes** pane populates.

9. Click the **Set** button.

10. Click the **Apply** button.

A **Do you want to apply?** prompt displays in a pop-up window.

11. Click the **Yes** button.

12. “**The requested operation is complete**” prompt displays in a pop-up window

Click the **OK** button.

13. Repeat Step 1 through Step 12 on RCU storage system to add a journal group on the RCU.

Configure Remote Replication Using CCI

Hitachi Command Control Interface software (CCI) has two components, one residing on the storage system and another residing on the server. The CCI components residing on the storage system are the command devices and the ShadowImage volumes (PVOLs, SVOLs). The components residing on the servers are the Hitachi Open Remote Copy Manager, also known as HORCM, the configuration definition files (for example, `horcm1.conf`) and the CCI commands. Although the Hitachi Universal Replicator software residing on the MCU and RCU storage systems maintains the replication of data between the P-VOLs on MCU and the S-VOLs on RCU, the CCI software allows you to manage, monitor and control the Hitachi Universal Replicator process.

The HORCM operational environment operates as a daemon process on the host server. When HORCM is activated, it refers to the configuration definition files. The HORCM instance communicates with the storage system and remote servers. Hitachi Universal Replicator software requires two HORCM instances one to manage the P-VOLs and the other to manage the S-VOLs. The HORCM configuration file defines the communication path and the logical units (LDEVs) to be controlled. Each HORCM instance has its own HORCM configuration file. The `horcm0.conf` and the `horcm1.conf` files used for this solution are available in Appendix B. Also, modify the `/etc/services` file to register the port name and number for each HORCM instance on each server. The entries for HORCM in the `/etc/services` file must be the same on all the servers. For example, for port name `horcm0` the service number might be `11000/udp` and for the port name `horcm1` the service number might be `11001/udp` in the `/etc/services` file on SAP ERP server at local and remote site. Figure 5 shows a two-server, two-HORCM instance configuration used for CCI for this solution.

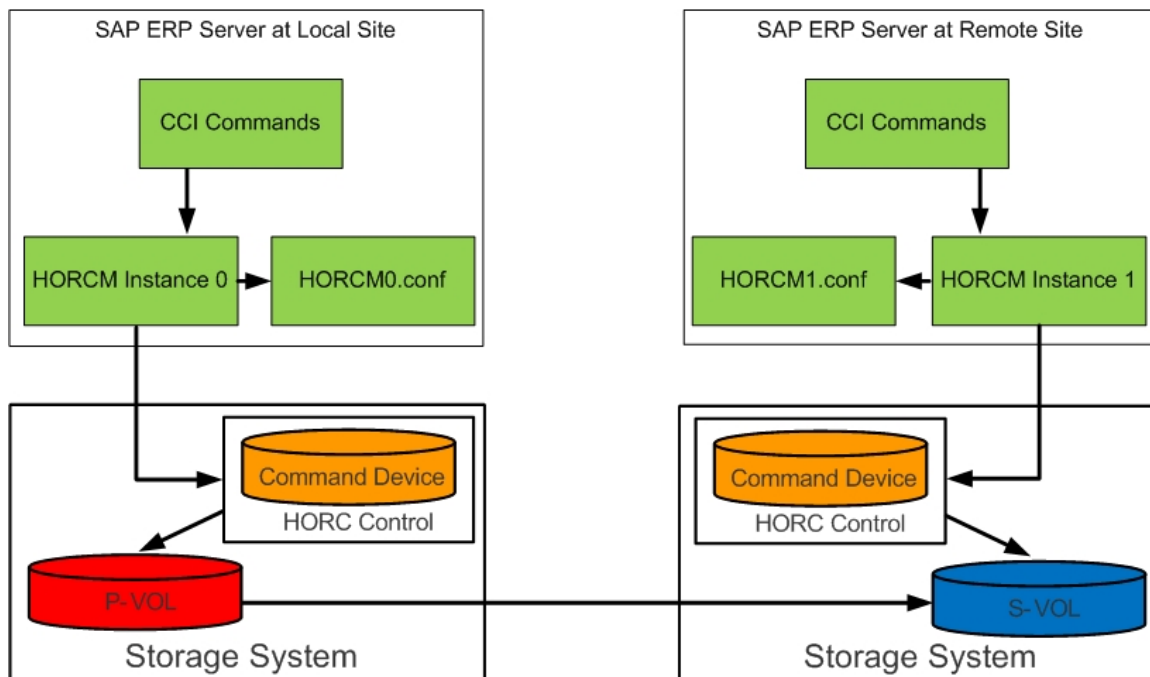

Figure 5

For more information about setting up the HORCM instances and HORCM configuration file, see the *Hitachi Command Control Interface (CCI) Users and Reference Guide* that accompanies the Hitachi Command Control Interface software.

After the HORCM instance is started on all the servers, CCI commands can be executed to manage, monitor and control remote replication between the servers. Table 8 lists CCI commands for Hitachi Universal Replicator software operations.

Table 8. CCI Commands for PAIR Operation

<i>Command Name</i>	<i>Description</i>	<i>Notes</i>
paircreate	Creates a new pair.	Status of P-VOL and S-VOL changes from SMPL to PAIR.
pairsplit	Splits pairs and create a point-in-time backup in the S-VOL by stopping the update of the secondary volume. The pair relationship of the P-VOL is maintained, and the differential information is also maintained.	Status of P-VOL changes from PAIR or COPY to PSUS. Status of S-VOL changes from PAIR or COPY to SSUS.
pairsplit -S	Discards the pair's differential information and deletes the pair.	Status of P-VOL changes to SMPL.
pairdisplay	Checks pair status and progress rate.	Use -l option in event of a failure when one of the sites is unavailable
horctakeover	Takes over operations from the local site to the remote site. It is also used to reverse the copy direction and re-establish the pair.	In the event of a local site failure, the status of S-VOL changes from PAIR to SSWS In the event of a planned failover, P-VOL becomes S-VOL and S-VOL becomes P-VOL
paircreate	Creates a new pair.	Status of P-VOL and S-VOL changes from SMPL to PAIR.
pairsplit	Splits pairs and create a point-in-time backup in the S-VOL by stopping the update of the secondary volume. The pair relationship of the P-VOL is maintained, and the differential information is also maintained.	Status of P-VOL changes from PAIR or COPY to PSUS. Status of S-VOL changes from PAIR or COPY to SSUS.

Implement Remote Replication for SAP ERP Server

For remote replication of the data on the SAP ERP server, initiate the base journal process by using the `paircreate` command on the SAP ERP server at the local site:

```
paircreate -g <group name> -vl -f <fence level> -jp -js <journal group ID>
```

For example:

```
paircreate -g SAP-HURG01 -vl -f async -jp 00 -js 00
```

When the `paircreate` command is executed, the initial copy is executed. The primary storage system copies all the data in sequence from the P-VOL directly to the S-VOL. During the initial copy process the status of the P-VOL and S-VOL is COPY. On completion of the initial copy process, the status of the P-VOL and S-VOL changes to PAIR. Any subsequent updates to the P-VOL are transferred to the S-VOL following the process described in the “Hitachi Universal Replicator Software Functionality” section.

The SAP ERP System deployment consists of SAP and Oracle binary files and database data. SAP ERP binary files and Oracle binary files are deployed on LDEVs that are separate from LDEVs containing database data. Because the solution described in this white paper installs and configures SAP ERP server at the remote site, the HORCM configuration files are defined in such a way that the Hitachi Universal Replicator creates pairs of the volumes containing database data only. Database data includes data files, log files and control files.

Recovering the SAP ERP Server During a Planned Failover

You might plan a failover of an SAP ERP server from a local site to a remote site for various reasons such as site migration, temporary failover to remote site for maintenance of local site, and so on. In a planned failover the applications at the local site are shutdown gracefully, Hitachi Universal Replicator software replicates any pending data that needs to be transferred to the remote site and applications are started at the remote site before servers and storage are shutdown on the local site.

To recover the SAP ERP server on the remote site during a planned failover, follow these steps:

1. Stop the SAP and the Oracle databases by executing the following command as SAP user on the local site:
`# stopsap`
2. Stop the Oracle listener by executing the following command as Oracle user on the local site:
`# lsnrctl stop`
3. Unmount the file systems containing database data, logs and control files of the local site.
4. On the remote site, execute the `horctakeover` command as a root user:
`# horctakeover -g SAP-HURG01 -t 60 -S`
5. The takeover switch function evaluates the status of P-VOLs and S-VOLs. Because the local volume is the S-VOL and the remote volume is the P-VOL and the status is PAIR, a SWAPTAKEOVER function is selected and the S-VOL is suspended to allow swapping of the P-VOL. Resync for the S-VOL is executed so that the S-VOL becomes the P-VOL. The new P-VOL is resynchronized with the new S-VOL.
6. Mount the file system containing database data on the SAP ERP server on the remote site.
7. Start Oracle listener by executing the following command as Oracle user on the remote site.
`# lsnrctl start`
8. Start SAP and Oracle database by issuing the following command as SAP user on the SAP Server on the remote site:
`# startsap`

The SAP ERP system on the remote is now available on the remote site for business processing.

Recovering SAP ERP Server After a Local Site Disaster

In a disaster scenario where the local site is completely unavailable and the links between the local site and remote site are broken, it is possible that some of the data from the MCU might not be applied at the RCU. In this scenario, an incomplete recovery of the database must be performed at the remote site leading to loss of some data.

To recover SAP ERP server on the remote site after a disaster at the local site, follow these steps:

1. On the remote site execute `horctakeover` command as a root user:

```
# horctakeover -g SAP-HURG01 -t 60
```
2. The takeover switch function determines that the command was executed at the S-VOL site and tries to determine the status of P-VOL. Because the status of P-VOL is unknown, the takeover function executes an S-VOL takeover and changes the status of S-VOL from PAIR to SSWS with an assumption that local site cannot be accessed. The S-VOL with SSWS status can be mounted for host I/O operations.
3. Mount the file system containing database data on the SAP ERP server at the remote site.
4. Start the Oracle database in mount state at the remote site by executing the following command:

```
SQLPLUS> startup mount;
```
5. Identify if a recovery of the database is required.

Note: It is important to verify whether a database recovery is needed.
6. If the database recovery is not required, go to Step 8.
7. If the database recovery is required, identify the type of recovery to be used.

In most cases, an incomplete recovery with a backup control file is required. You can initiate it by executing the following command:

```
SQLPLUS> recover database;
```
8. Open the database using the `RESETLOGS` option by executing the following command on the SAP ERP server on the remote site:

```
SQLPLUS> alter database open;
```
9. Shut down the database by executing the following command on the SAP ERP server at the remote site:

```
SQLPLUS> Shut down;
```
10. Start Oracle listener by executing the following command as Oracle user on the SAP ERP server at the remote site:

```
# lsnrctl start
```
11. Start SAP and the Oracle database by executing the following command as SAP user on the SAP ERP server at the remote site:

```
# startsap
```

The SAP ERP system at the remote is now available for business processing.

Appendix A: Database Parameter Files for Remote Replication of SAP System

Hitachi Data Systems used the following files for remote replication of an SAP ERP system at the local site on to the instance at remote site:

- Oracle server parameter file on the SAP ERP server at local site
- Oracle server parameter file on the SAP ERP server at remote site

Oracle Server Parameter File on the SAP ERP Server at Local Site

#FileName: initPRD.ora

```
*. _B_TREE_BITMAP_PLANS=FALSE
*. _IN_MEMORY_UNDO=FALSE
*. _INDEX_JOIN_ENABLED=FALSE
*. _OPTIM_PEEK_USER_BINDS=FALSE
*. _OPTIMIZER_MJC_ENABLED=FALSE
*. _SORT_ELIMINATION_COST_RATIO=10
*. _TABLE_LOOKUP_PREFETCH_SIZE=0
*. background_dump_dest='/oracle/PRD/saptrace/background'
*. compatible='10.2.0'
*. control_file_record_keep_time=30
*. control_files='/oracle/PRD/origlogA/cntrl/cntrlPRD.dbf', '/oracle/PRD/origlogB/cntrl/cntrlPRD.dbf', '/oracle/PRD/sapdata1/cntrl/cntrlPRD.dbf'
*. core_dump_dest='/oracle/PRD/saptrace/background'
*. db_block_size=8192
*. db_cache_size=9133306675
*. db_files=254
*. db_name='PRD'
*. dml_locks=4000
*. event='10191 trace name context forever, level 1'
*. FILESYSTEMIO_OPTIONS='setall'
*. job_queue_processes=1
*. log_archive_dest='/oracle/PRD/saparch/PRDarch'
*. log_buffer=1048576
*. log_checkpoint_interval=0
```

```

*.log_checkpoint_to_alert=true
*.open_cursors=800
*.parallel_execution_message_size=16384
*.pga_aggregate_target=12177742233
*.processes=80
*.query_rewrite_enabled='false'
*.recyclebin='off'
*.remote_login_passwordfile='exclusive'
*.remote_os_authent=true
*.replication_dependency_tracking=false
*.sessions=96
*.sga_max_size=18266613350
*.shared_pool_reserved_size=913330667
*.shared_pool_size=9133306675
*.sort_area_retained_size=0
*.sort_area_size=2097152
*.star_transformation_enabled='true'
*.undo_management='AUTO'
*.undo_retention=43200
*.undo_tablespace='PSAPUNDO'
*.user_dump_dest='/oracle/PRD/saptrace/usertrace'

```

Oracle Server Parameter File on the SAP ERP Server at Remote Site

```

#FileName: initPRD.ora
*._B_TREE_BITMAP_PLANS=FALSE
*._IN_MEMORY_UNDO=FALSE
*._INDEX_JOIN_ENABLED=FALSE
*._OPTIM_PEEK_USER_BINDS=FALSE
*._OPTIMIZER_MJC_ENABLED=FALSE
*._SORT_ELIMINATION_COST_RATIO=10
*._TABLE_LOOKUP_PREFETCH_SIZE=0
*.background_dump_dest='/oracle/PRD/saptrace/background'

```

```
*. compatible=' 10. 2. 0'
*. control_file_record_keep_time=30
*. control_files=' /oracl e/PRD/ori gl ogA/cntrl /cntrl PRD. dbf' , ' /oracl e/PRD/ori gl
ogB/cntrl /cntrl PRD. dbf' , ' /oracl e/PRD/sapdata1/cntrl /cntrl PRD. dbf'
*. core_dump_dest=' /oracl e/PRD/saptrace/background'
*. db_block_si ze=8192
*. db_cache_si ze=9133306675
*. db_fi les=254
*. db_name=' PRD'
*. dml_l ocks=4000
*. event=' 10191 trace name context forever, level 1'
*. FILESYSTEMI O_OPTI ONS=' setal l'
*. j ob_queue_processes=1
*. log_archi ve_dest=' /oracl e/PRD/saparch/PRDarch'
*. log_buffer=1048576
*. log_checkpoi nt_i nterval =0
*. log_checkpoi nts_to_al ert=true
*. open_cursors=800
*. paral lel_executi on_message_si ze=16384
*. pga_aggregate_target=12177742233
*. processes=80
*. query_rewri te_enabl ed=' fal se'
*. recycl ebi n=' off'
*. remote_l ogi n_passwordfi le=' excl usi ve'
*. remote_os_authent=true
*. repl i cati on_dependency_tracki ng=fal se
*. sessi ons=96
*. sga_max_si ze=18266613350
*. shared_pool _reserved_si ze=913330667
*. shared_pool _si ze=9133306675
*. sort_area_retai ned_si ze=0
*. sort_area_si ze=2097152
*. star_transformati on_enabl ed=' true'
```

```
*. undo_management=' AUTO'  
*. undo_retention=43200  
*. undo_tablespace=' PSAPUNDO'  
*. user_dump_dest=' /oracle/PRD/saptrace/usertrace'
```

Appendix B: ShadowImage Configuration Files

ShadowImage configuration files consist of following sections:

- **HORCM_MON** - Contains information need to monitor a HORCM instance such as IP address, HORCM instance or service, pooling interval for monitoring paired volumes and timeout period for communication with remote server.
- **HORCM_CMD** - Contains device path information about the command device.
- **HORCM_LDEV** - Defines the storage sub-system device address for the paired logical volume names.
- **HORCM_INST** - Network address of the remote server.

ShadowImage Configuration Files for SAP ERP Server at Local Site

#FileName: horcm0.conf

#!/***** For HORCM_MON *****/

HORCM_MON

#i p_address	servi ce	pol l (10ms)	t i meout (10ms)
172. 17. 171. 143	horcm0	1000	3000

#!/***** For HORCM_CMD *****/

HORCM_CMD

#dev_name

/dev/sdq

#!/***** For HORCM_LDEV *****/

HORCM_LDEV

#dev_group	dev_name	Serial #	CU: LDEV(LDEV#)	MU#
SAP- HURG01	SAP_Logs_PV1	53101	03: 04	0
SAP- HURG01	SAP_Logs_PV2	53101	03: 05	0
SAP- HURG01	SAP_Logs_PV3	53101	03: 06	0
SAP- HURG01	SAP_Logs_PV4	53101	03: 07	0
SAP- HURG01	SAP_Arch_1	53101	03: 08	0
SAP- HURG01	SAP_Data_1	53101	03: 09	0
SAP- HURG01	SAP_Data_2	53101	03: 0A	0
SAP- HURG01	SAP_Data_3	53101	03: 0B	0
SAP- HURG01	SAP_Data_4	53101	03: 0C	0
SAP- HURG01	SAP_Data_5	53101	03: 0D	0

```
#!/***** For HORCM_INST *****/
```

```
HORCM_INST
```

```
#dev_group ip_address service
```

```
SAP-HURG01 172.17.171.144 horcm1
```

ShadowImage Configuration Files for SAP ERP Server at Remote Site

```
#FileName: horcm1.conf
```

```
#!/***** For HORCM_MON *****/
```

```
HORCM_MON
```

```
#ip_address service poll(10ms) timeout(10ms)
```

```
172.17.171.144 horcm1 1000 3000
```

```
#!/***** For HORCM_CMD *****/
```

```
HORCM_CMD
```

```
#dev_name dev_name
```

```
/dev/sdq /dev/sdr
```

```
#!/***** For HORCM_LDEV *****/
```

```
HORCM_LDEV
```

```
#dev_group dev_name Serial # CU: LDEV(LDEV#) MU#
```

```
SAP-HURG01 SAP_Logs_PV1 53119 03:04 0
```

```
SAP-HURG01 SAP_Logs_PV2 53119 03:05 0
```

```
SAP-HURG01 SAP_Logs_PV3 53119 03:06 0
```

```
SAP-HURG01 SAP_Logs_PV4 53119 03:07 0
```

```
SAP-HURG01 SAP_Arch_1 53119 03:08 0
```

```
SAP-HURG01 SAP_Data_1 53119 03:09 0
```

```
SAP-HURG01 SAP_Data_2 53119 03:0A 0
```

```
SAP-HURG01 SAP_Data_3 53119 03:0B 0
```

```
SAP-HURG01 SAP_Data_4 53119 03:0C 0
```

```
SAP-HURG01 SAP_Data_5 53119 03:0D 0
```

```
#!/***** For HORCM_INST *****/
```

```
HORCM_INST
```

```
#dev_group ip_address service
```

```
SAP-HURG01 172.17.171.143 horcm0
```

 **Hitachi Data Systems Corporation**

Hitachi is a registered trademark of Hitachi, Ltd., in the United States and other countries. Hitachi Data Systems is a registered trademark and service mark of Hitachi, Ltd., in the United States and other countries. All other trademarks, service marks and company names mentioned in this document are properties of their respective owners.

Notice: This document is for informational purposes only, and does not set forth any warranty, expressed or implied, concerning any equipment or service offered or to be offered by Hitachi Data Systems Corporation

© Hitachi Data Systems Corporation 2010. All Rights Reserved. AS-083-00 April 2011

Corporate Headquarters

750 Central Expressway,
Santa Clara, California 95050-2627 USA
www.hds.com

Regional Contact Information

Americas: +1 408 970 1000 or info@hds.com
Europe, Middle East and Africa: +44 (0) 1753 618000 or info.emea@hds.com
Asia Pacific: +852 3189 7900 or hds.marketing.apac@hds.com