

# Local Replication of SAP Systems on the Hitachi Virtual Storage Platform

Implementation Guide

*By Archana Kuppuswamy*

*March 2011*



## Feedback

Hitachi Data Systems welcomes your feedback. Please share your thoughts by sending an email message to [SolutionLab@hds.com](mailto:SolutionLab@hds.com). Be sure to include the title of this white paper in your email message.

# Table of Contents

<b>Tested Solution Components</b> .....	<b>4</b>
Hardware Components .....	5
Software Components.....	7
<b>Solution Implementation</b> .....	<b>9</b>
Configure the Storage Area Network .....	9
Configure Servers and the Operating Environment .....	10
Configure Storage .....	12
Install and Configure SAP software .....	22
Configure ShadowImage Heterogeneous Replication for Off-host Processing .....	22
Replicate the SAP ERP System.....	25
<b>Appendix A — Parameter Files for Replicating SAP Systems Using the Same SIDs</b> .....	<b>32</b>
BRBackup Configuration File .....	32
Script File for Splitting P-VOLs and S-VOLs .....	32
Oracle Server Parameter File on the SAP ERP Server .....	33
Oracle Server Parameter File on the SAP ERP Off-host Server .....	34
<b>Appendix B — Parameter Files for Replicating SAP Systems Using Different SIDs</b> .....	<b>36</b>
BRBackup Configuration File .....	36
Script File for Splitting P-VOLs and S-VOLs .....	36
Oracle Server Parameter File on the SAP ERP Server .....	37
Oracle Server Parameter File on the SAP ERP Off-host Server .....	38
<b>Appendix C — Change CCI User from root to ora&lt;SID&gt; User</b> .....	<b>40</b>
<b>Appendix D — Hitachi ShadowImage Heterogeneous Replication Configuration Files</b> ....	<b>42</b>
ShadowImage Heterogeneous Replication Configuration Files for SAP ERP Server .....	42
ShadowImage Heterogeneous Replication Configuration Files for SAP ERP Off-host Server	43

# Local Replication of SAP systems on the Hitachi Virtual Storage Platform

## Implementation Guide

Most SAP customers rely on their IT environments to be available 24 hours a day, seven days a week. They cannot tolerate any process that might have a negative effect on the production instance's performance or availability. Given the critical nature of most SAP deployments, it is important to have a secondary copy of the production landscape's data available for a variety of processes.

One of the most powerful capabilities of an advanced storage infrastructure is the ability to create multiple copies of data with minimal effect on the production instance. These copies are used for a variety of purposes: backup, data mining, test environments and so on. Although this capability is extremely powerful, it can also be one of the most complex storage administration tasks. Introducing any process into a production SAP environment requires detailed planning and testing to ensure that the process does not impact production and that it is documented and can be repeated.

Hitachi takes a holistic approach to SAP environments, and the key to that approach is the Hitachi Virtual Storage Platform. The advanced functionalities of the Hitachi Virtual Storage Platform fulfill the complex and demanding requirements of an SAP implementation like data replication. Although data replication can be performed at the server level, this function is more effectively performed within the storage infrastructure.

The Hitachi Virtual Storage Platform is the industry's only 3D scaling storage platform. With the unique ability to concurrently scale up, scale out and scale deep in a single storage system, the Virtual Storage Platform is adaptable to varying performance, capacity, connectivity and virtualization requirements. No other enterprise storage platform can dynamically scale in three dimensions. Scaling up allows you to increase virtual server consolidation, improve utilization of resources, and reduce costs. Scaling out allows you to meet increasing demands by combining multiple chassis into a single logical system with shared resources. Scaling deep extends the advanced functions of the Virtual Storage Platform to external multivendor storage.

The solution described in this white paper uses the Hitachi Virtual Storage Platform and Hitachi ShadowImage® Heterogeneous Replication software to replicate an SAP Production ERP instance and prepare the copy for access by a secondary server. It provides step-by-step instructions for preparing the environment for replication, configuring replication and implementing replication for off-host processing

This white paper is written for IT professionals who are charged with storage or SAP deployment or administration. It assumes basic knowledge of storage area network concepts and operating practices.

## Tested Solution Components

This white paper describes a solution that includes SAP clients that access the SAP application infrastructure for on-host as well as off-host processing, which in turn stores data in and accesses data from a Hitachi Virtual Storage Platform family storage system, as illustrated by Figure 1.

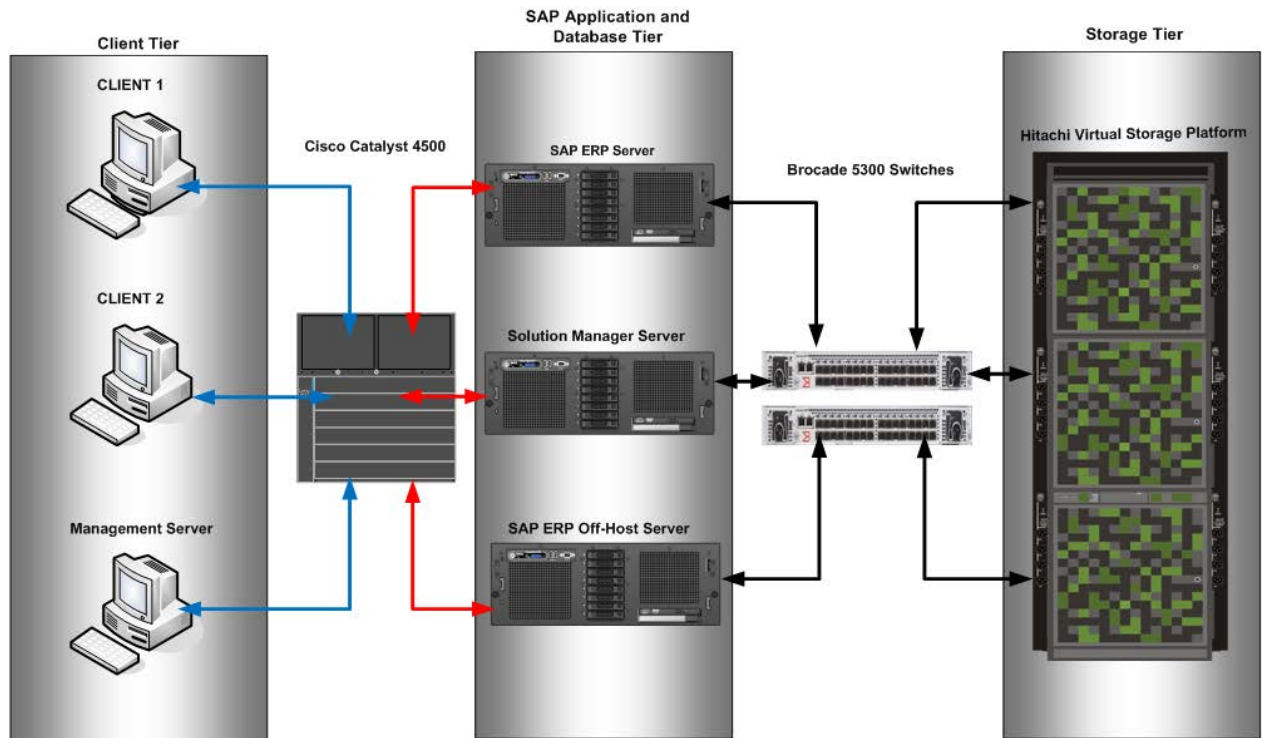

Figure 1

In the tested deployment, the SAP client tier consists of Windows-based servers with the SAP GUI installed. The clients connect to the SAP system in the SAP application tier via a Cisco Catalyst 4500 switch. Storage Navigator is installed on a Windows based management server in the client tier. The SAP ERP, ERP off-host and the Solution Manager servers are installed on Linux servers in the SAP Application and Database tier. The SAP ERP, ERP off-host and the Solution Manager systems are installed as a central system which means that both the SAP application and database are installed on a single server. All the SAP application servers are connected to the Hitachi Virtual Storage Platform via two Brocade 5300 switches.

The following sections describe the hardware and software components required to deploy the solution described in this white paper.

## Hardware Components

Table 1 describes the hardware used to deploy this solution in the Hitachi Data Systems lab.

**Table 1. Tested Deployment Hardware**

<i>Hardware</i>	<i>Quantity</i>	<i>Configuration</i>	<i>Role</i>
Hitachi Virtual Storage Platform System	1	Firmware version 70-00-53-00/00 8 Fibre Channel ports used 2 pair of front-end directors 2 pair of back-end directors 64 x 300GB 10K RPM Fibre Channel drives 64GB cache;14GB shared memory	Primary storage
Brocade 5300 SAN Fibre Channel switch	1	FOS 6.4.0E SAN switch with 8Gbps Fibre Channel ports	SAN switch
Server	1	6 Intel Xeon processors X5650 2.67GHz, 16GB memory	SAP Solution Manager server
Server	1	6 Intel Xeon processors X5650 2.67GHz, 16GB memory	SAP ERP server
Server	1	6 Intel Xeon processors X5650 2.67GHz, 16GB memory	SAP ERP off-host server
Server	2	Intel Pentium 3.0GHz processor 1GB memory	SAP clients
Server	1	Intel Pentium 3.0GHz processor 1GB memory	Management server with access to Hitachi Storage Navigator software

### *Hitachi Virtual Storage Platform*

The Hitachi Virtual Storage Platform is the industry's only 3D scaling storage platform. With the unique ability to concurrently scale up, scale out and scale deep in a single storage system, the Virtual Storage Platform flexibly adapts for performance, capacity, connectivity and virtualization. No other enterprise storage platform can dynamically scale in three dimensions. The Virtual Storage Platform provides virtual storage that meets the growing demands of server virtualization.

The trend in server virtualization is to consolidate the I/O workload of many servers onto a single storage system. As more virtual machines are consolidated onto a physical host, storage systems must be able to dynamically add more storage resources to keep up with I/O demand. The 3D scaling capability of the Virtual Storage Platform meets that requirement.

Scaling up allows you to increase virtual server consolidation, improve utilization of resources, and reduce costs. With the Hitachi Virtual Storage Platform, you can increase performance, capacity and connectivity by adding cache, processors, connections and disks to the base system. A virtual server that accesses the storage system can use all these resources, which act as one system managed as a common pool of resources.

Scaling out allows you to meet increasing demands by combining multiple chassis into a single logical system with shared resources. By scaling out you can support increased resource needs in virtualized server environments.

Scaling deep extends the advanced functions of the Virtual Storage Platform to external multivendor storage. By dynamically virtualizing new and existing storage systems, those systems become part of the Virtual Storage Platform's pool of storage resources. Once virtualized, external data can then be migrated, tiered, replicated and managed by the Virtual Storage Platform. In this manner, older data storage systems can gain a longer useful life. You can extend distance replication for business continuity to lower-cost, lower-function storage systems by virtualizing them behind a Virtual Storage Platform.

The switch matrix architecture of the Virtual Storage Platform makes all of this possible. It connects the basic components, front-end directors, back-end directors, global cache modules and virtual storage directors. You can add redundant pairs of directors and cache modules as required without disruption to connected host servers. All these resources are tightly coupled through a global cache that creates a common pool of storage resources. These resources can include external storage that is connected through front-end director initiator ports.

For more information about the Hitachi Virtual Storage Platform, see the Hitachi Data Systems [web site](#).

### *SAP Servers*

Servers must meet specification requirements for the SAP Solution Manager and SAP ERP roles they are hosting. For more information about server requirements for SAP ERP, SAP Solution Manager and SAP clients, see the following SAP Notes, which are available to licensed customers from SAP's Web site:

- SAP Note 1094599, Installation NW7-SR3/Business Suite 2005 SR3 Unix/Oracle
- SAP Note 26147, SAP GUI Resources: Hardware and Software
- SAP Note 901070, Resource Requirements for SAPECC6

## Software Components

Table 2 lists the software used to test this solution in the Hitachi Data Systems lab.

**Table 2. Tested Deployment Software**

<i>Software</i>	<i>Version</i>
Hitachi Storage Navigator	Microcode dependent
Hitachi Command Control Interface (CCI)	01-24
Hitachi ShadowImage Heterogeneous Replication	Licensed feature available with Hitachi Virtual Storage Platform
Hitachi Dynamic Provisioning Software	Licensed feature available with Hitachi Virtual Storage Platform
Hitachi Dynamic Link Manager Advanced	6.0.1.0.804
SAP ERP IDES	6.0 Support Release 3 (SR3) with Enhancement Pack 4 IDES
SAP Solution Manager	7.0 Enhancement Package 1 on SP 25
SAP GUI	7.2
Oracle Database 10g Enterprise Edition	10.2.0.4

### *Hitachi Storage Navigator Software*

Hitachi Storage Navigator software is the integrated interface for the Virtual Storage Platform family firmware and software features. Use it to take advantage of all of the Virtual Storage Platform's features. Storage Navigator software provides a web-accessible graphical management interface.

Storage Navigator software is used to map security levels for SAN ports and virtual ports and for inter-system path mapping. It is used for logical unit (LDEV) creation and expansion, and for online volume migrations. It also configures and manages Hitachi replication products. It enables online microcode updates and other system maintenance functions and contains tools for SNMP integration with enterprise management systems.

### *Hitachi ShadowImage Heterogeneous Replication Software*

Hitachi ShadowImage Heterogeneous Replication software is a storage-based hardware solution that creates RAID-protected duplicate volumes within the Hitachi Virtual Storage Platform family. ShadowImage primary volumes (P-VOLs) contain the original data and up to nine secondary volumes (S-VOLs) can be created as copies.

On the Hitachi Virtual Storage Platform, ShadowImage Heterogeneous Replication software is used to implement clones, a full copy of the primary data. A copy of the primary data is made and the copy is then available to be used by secondary applications. The unique value of working with a clone is that once the clone is created, any operations on the clone have no effect on the primary data. ShadowImage Heterogeneous Replication software functions are made available through Hitachi Storage Navigator software GUI and Hitachi Command Control Interface (CCI).

## *Hitachi Dynamic Provisioning Software*

On the Virtual Storage Platform, Hitachi Dynamic Provisioning software provides wide striping and thin provisioning functionalities. Hitachi Dynamic Provisioning software provides for one or more pools of storage across many RAID groups within a Virtual Storage Platform. One or more Dynamic Provisioning virtual volumes (DP-VOLs) of a user-specified logical size of up to 60TB (with no initial physical space allocated) are created against each pool.

Hitachi Dynamic Provisioning software provides features that provide virtual storage capacity to eliminate application service interruptions, reduce costs, and simplify administration, as follows:

- Optimizes or “right-sizes” storage performance and capacity based on business or application requirements.
- Supports deferring storage capacity upgrades to align with actual business usage.
- Simplifies and adds agility to the storage administration process.
- Improves performance

## *Hitachi Dynamic Link Manager Advanced Software*

Hitachi Dynamic Link Manager Advanced software bundles Hitachi Dynamic Link Manager I/O multipathing software and Hitachi Global Link Manager software. Hitachi Dynamic Link Manager software, which is installed on the SAP ERP and SAP Solution Manager servers, includes capabilities such as path failover and failback and automatic load balancing to provide higher data availability and accessibility.

In this solution, Hitachi Dynamic Link Manager Advanced software is installed on the three SAP servers.

## *SAP Software*

SAP ERP combines scalable and effective software for enterprise resource planning (ERP) with a flexible, open technology platform that can leverage and integrate SAP and non-SAP systems. SAP provides end-to-end software functionality for enterprise management.

SAP Solution Manager is a service and support platform that provides the integrated content, tools and methodologies to implement, support and monitor operations of SAP implementation. Solution Manager is installed on a separate system. Hitachi Data Systems uses the Solution Manager server for these functions:

- Configuring installation keys for the install of any SAP ABAP and Java instance
- Approving the download of any updates from SAP like service packs or enhancement packs
- Installing SAP enhancement packs onto ABAP instances
- Obtaining support from SAP

SAP GUI is the client software that allows SAP users to access various functionalities in SAP applications and SAP Solution Manager.

SAP systems can be used with a variety of databases available from different vendors. The business transactions in SAP systems are processing units grouped to provide specific functions; these processing units execute changes to the database that are consistent. In this solution the ERP and Solution Manager systems at local and remote site are installed on Oracle database.

SAP BRBackup is a backup and recovery tool for Oracle databases that allows you to take variety of backups such as online backups, offline backups, tape backups, split mirror backup, and so on.

## Solution Implementation

Deploying this solution requires these following high-level steps:

1. Configure the storage area network.
2. Configure servers and the operating environment.
3. Configure storage.
4. Install and configure SAP software.
5. Configure ShadowImage Heterogeneous Replication for off-host processing.
6. Replicate the SAP ERP system

Your checklist might vary based on your environment. More details about each of these steps are included in the following sections.

### Configure the Storage Area Network

When deploying an SAP system, the storage used by SAP Solution Manager server, SAP ERP server and SAP ERP off-host server must be isolated from each other in a SAN. As shown in Figure 2, six separate Fibre Channel zones are created, one from each HBA of the SAP Solution Manager server, SAP ERP server and SAP ERP off-host server. The Fibre Channel zones for the SAP Solution Manager, SAP ERP server and SAP ERP off-Host server do not share Fibre Channel ports on the storage system.

World wide names (WWNs) of the HBAs residing on a physical server can be assigned to a host group and then an LDEV can be associated with each host group. This means that a group of LDEVs can be isolated to be used by only the assigned physical servers.

The SAP ERP server, SAP ERP off-host server and the Solution Manager server are connected via two HBAs in each server to two Brocade 5300 switches. The Brocade 5300 switches, in turn, are connected to six different ports of the Hitachi Virtual Storage Platform.

The Hitachi Virtual Storage Platform supports active-active multipath connectivity. To obtain maximum availability, design and implement your host-storage connections so that at least two unique paths exist from the host to the storage system. Hitachi Data Systems recommends the use of dual SAN fabrics, multiple HBAs and host-based multipathing software when deploying SAP systems. This solution uses Hitachi Dynamic Link Manager for the multipathing software.

The choice of load-balancing algorithm depends on the specific environment and access patterns of the application. In most cases, the extended round robin algorithm provides the best overall performance. In some environments, such as an environment shared with other applications, one of the other algorithms might give the best overall performance.

Figure 2 illustrates zones and the redundant paths that are managed by Hitachi Dynamic Link Manager Advanced software in the deployment tested for this solution.

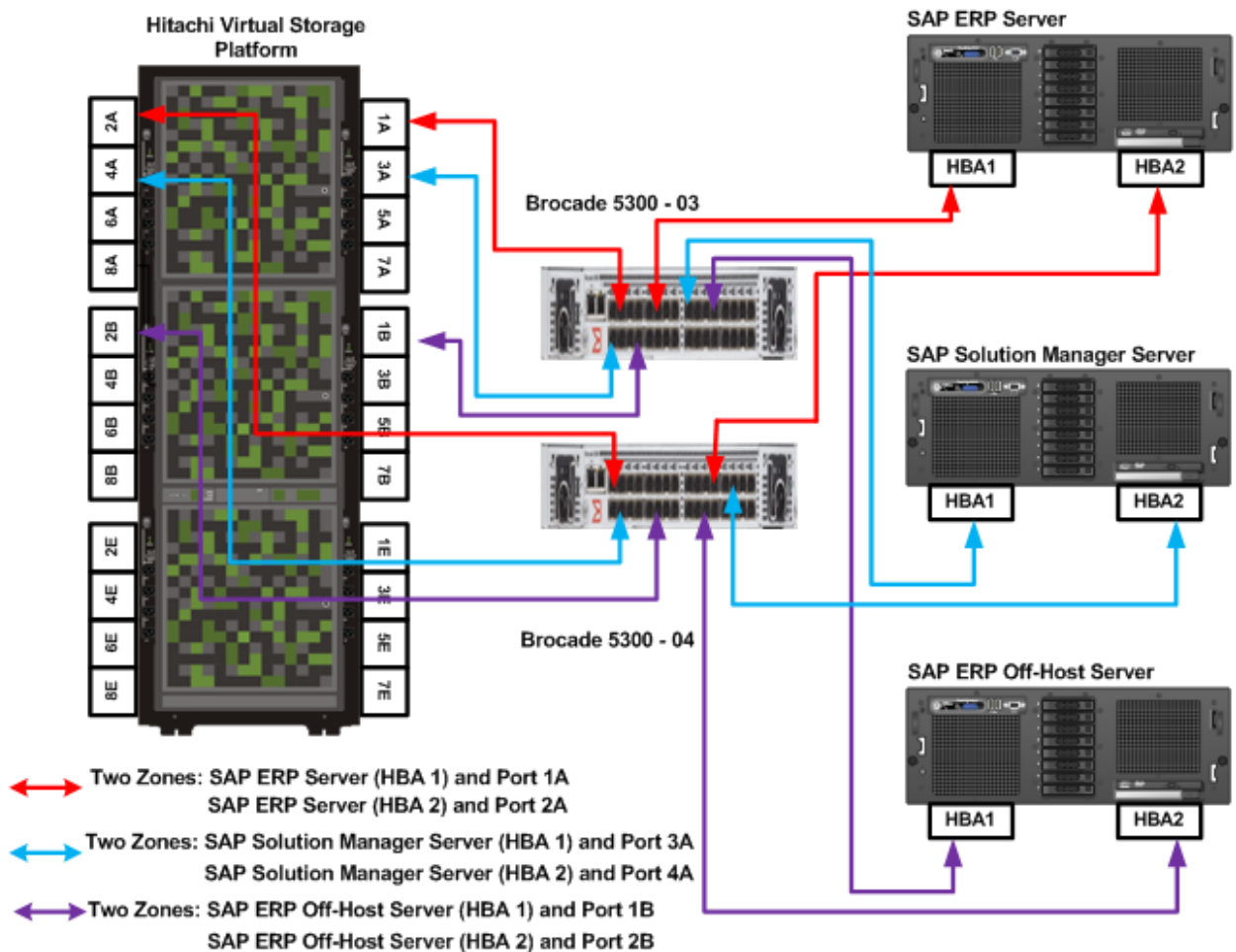

Figure 2

## Configure Servers and the Operating Environment

Configure SAP Solution Manager, SAP ERP server and SAP ERP off-host server according to their specific installation guides. These guides are available to licensed customers at the [SAP Service Marketplace](#). Deploy the SAP ERP off-host server following the same guidelines as used for the SAP ERP server. Depending on the workload required by the SAP ERP off-host server, users can either use high-end servers that provide availability, scalability and performance or any other supported server that meets the processing needs of the off-host server. However, use of highly available and scalable storage systems is a necessity for implementing SAP replication.

The SAP ERP off-host server has the same server, storage, operating system and software configuration as the SAP ERP server, with one possible difference: Depending on the type of off-host processing, it is important to determine if the same system identifier (SID) for SAP ERP and Oracle is required on the off-host server or if different SIDs for SAP and Oracle are required. For off-host processing such as backup of production SAP system from an off-host server, it might be necessary to have the same SID as the SAP system, but for off-host processing such as testing, training, reporting and so on, an SID that is different from the production SAP system might be required.

This white paper describes two scenarios, one to replicate the SAP system using the same SID and the second one to replicate the SAP system with a different SID. The first scenario fulfills the need to have a backup copy of the production instance and the second scenario fulfills the requirement to have multiple copies of data from the production instance for various purposes like testing, training and development systems, refreshing QA, reporting and data mining environments. For the first scenario Hitachi Data Systems performed local replication between two SAP systems with the same SID and for the second scenario Hitachi Data Systems performed local replication of data between the primary production instance and the secondary system, a development system.

This solution requires that the user number (UID) and the group number (GID) for the SAP software owner and Oracle users are the same on the SAP ERP server and the SAP ERP off-host server. Although the underlying RAID configuration, RAID type and disk type for the storage remain the same for the off-host server, the file system mount points might change based on the SID.

When deploying SAP Solution Manager, SAP ERP software and SAP ERP off-host server for this solution, Hitachi Data Systems used three servers with six CPUs and 16GB memory. Each server has two Fibre Channel host bus adapters (HBAs) and two 1GB network interface cards. Two SAP client servers and one management server for access to Hitachi Storage Navigator software were deployed using servers with two CPUs and 1GB memory.

Hitachi Data Systems installed Red Hat Enterprise Linux version 5.2 (x86 64 bit) on the SAP Solution Manager, SAP ERP and off-host servers. Microsoft Windows 2008 was installed on the SAP clients and the management server.

For more information about supported operating systems, see the following SAP Notes, which are available to licensed customers from SAP's [web site](#):

- SAP Note 171356, *SAP Software on Linux: Essential*
- SAP Note 1048303, *Red Hat Enterprise Linux 5.x: Installation and Upgrade*
- SAP Note 1172419, *Linux: Supported Java Versions on the x86\_64 Platform*

### ***Complete SAP Pre-installation Tasks***

You must complete several pre-installation tasks before installing either SAP Solution Manager or SAP ERP software or configuring your storage. For more information about pre-installation tasks, see the following SAP Notes, which are available to licensed customers from SAP's [web site](#):

- SAP Note 855498, *Installation Pre-requisite Checker, SAP Guides*
- SAP Note 1145779, *SAP Solution Manager 7 Installation*
- SAP Note 1052298, *SAP NetWeaver 7.0(2004s) SR3 Installation on UNIX/Oracle*
- SAP Note 830576, *Parameter Recommendations for Oracle 10g*
- SAP Note 1289199, *Information about Oracle Parameters*

- SAP Note 828268, *Oracle Database 10g: New Functions*
- SAP Note 871735, *Current Patch Set for Oracle 10.2.0*

Hitachi Data Systems recommends using a logical volume manager (LVM) to create volume groups and logical volumes. For this solution, the logical volumes, volume groups and file systems are laid out based on the application needs. The SAP Solution Manager Server, the SAP ERP server and off-host server use similar volume group, logical volume and file system configuration.

## Configure Storage

The following sections describe how to configure your storage for this solution. For this solution, Hitachi Data Systems used Hitachi Dynamic Provisioning software to provision storage for the databases. Use Hitachi Storage Navigator software to create and manage the storage objects.

Standard LDEVs were used for the logs, which includes online redo logs, mirrored logs and the archived logs for all of the SAP servers. Dynamic Provisioning volumes (DP-VOLs) were used for all the other logical volumes of the servers.

To ensure that the failure of a disk that contains a data file does not also cause the loss of the redo logs needed to recover the data file in this solution we store the online redo logs, mirrored logs and archived log files on disks separate from that of the data files.

Three Dynamic Provisioning pools were created for the SAP databases, one for each SAP server. All RAID groups used to create the Dynamic Provisioning pools were configured as RAID-5 (3D+1P). All drives were 300GB 10K RPM SAS drives. A total of four RAID groups were used for each of the three Dynamic Provisioning pools, giving each pool a storage capacity of 3.14TB. Nine DP-VOLs were configured per Dynamic Provisioning pool.

Table 3 lists the configuration of the Dynamic Provisioning pools created for the SAP servers.

**Table 3. Hitachi Dynamic Provisioning Pool Configuration**

<i>Dynamic Provisioning Pool</i>	<i>Role</i>
SAP_SOL	SAP Solution Manager server
SAP_ERP	SAP ERP server
SAP_ERP_OFFHOST	SAP ERP off-host server

Table 4 lists storage configuration details for LDEVs created for the SAP Solution Manager server in the SAP\_SOL pool. All LDEVs were mapped to storage ports 3A and 4A.

**Table 4. LDEV Storage Configuration for the SAP Solution Manager Server**

<i>LDEV</i>	<i>Host LUN</i>	<i>Size (GB)</i>
00:02:00	00	50
00:02:01	01	50
00:02:02	02	50
00:02:03	03	50
00:02:09	09	200
00:02:0A	0A	200
00:02:0B	0B	200
00:02:0C	0C	200
00:02:0D	0D	200

Table 5 lists storage configuration details for LDEVs created for the SAP ERP server in the SAP\_ERP pool. All LDEVs were mapped to storage ports 1A and 2A.

**Table 5. LDEV Storage Configuration for the SAP ERP Server**

<i>LDEV</i>	<i>Host LUN</i>	<i>Size (GB)</i>
00:03:00	00	50
00:03:01	01	50
00:03:02	02	50
00:03:03	03	50
00:03:09	09	200
00:03:0A	0A	200
00:03:0B	0B	200
00:03:0C	0C	200
00:03:0D	0D	200
00:03:0E	0E	1

Table 6 lists storage configuration details for LDEVs created for the SAP ERP off-host server in the SAP\_ERP\_OFFHOST pool. All LDEVs were mapped to storage ports 1B and 2B.

**Table 6. LDEV Storage Configuration for the SAP ERP Off-host Server**

<i>LDEV</i>	<i>Host LUN</i>	<i>Size (GB)</i>
00:04:00	00	50
00:04:01	01	50
00:04:02	02	50
00:04:03	03	50
00:04:09	09	200
00:04:0A	0A	200
00:04:0B	0B	200
00:04:0C	0C	200
00:04:0D	0D	200
00:04:0E	0E	1

Two RAID-5 (3D+1P) RAID groups were used to store the SAP logs. This includes online redologs, mirrored logs and the archived logs of the SAP servers.

All drives were 300GB 10K RPM SAS drives. Each RAID group had a storage capacity of 900GB. Table 7 lists the RAID group configuration for the logs.

**Table 7. RAID Group Configuration for SAP Solution Manager Server, SAP ERP Server, SAP ERP off-host Server Logs**

<i>RAID Group ID</i>	<i>Number of LDEVs</i>
1-1	10
1-2	5

Table 8 lists the LUN configuration of RAID group 1-1 for the logs of SAP Solution Manager server and SAP ERP off-host server.

**Table 8. ERP and Solution Manager LDEV Configuration of RAID Group 1-1**

<i>LDEV</i>	<i>Host Group</i>	<i>Host LUN</i>	<i>Size (GB)</i>	<i>Server</i>
00:02:04	1	04	10	SAP Solution Manager
00:02:05	1	05	10	SAP Solution Manager
00:02:06	1	06	10	SAP Solution Manager
00:02:07	1	07	10	SAP Solution Manager
00:02:08	1	08	150	SAP Solution Manager
00:03:04	2	04	10	SAP ERP
00:03:05	2	05	10	SAP ERP
00:03:06	2	06	10	SAP ERP
00:03:07	2	07	10	SAP ERP
00:03:08	2	08	150	SAP ERP

Table 9 lists the LDEV configuration of RAID group 1-2 for the SAP ERP off-host server logs. All of these LDEVs are mapped to host group 3.

**Table 9. ERP Off-host LUN Configuration of RAID Group 1-2**

<i>LDEV</i>	<i>Host LUN</i>	<i>Size (GB)</i>	<i>Server</i>
00:04:04	04	10	SAP ERP off-host
00:04:05	05	10	SAP ERP off-host
00:04:06	06	10	SAP ERP off-host
00:04:07	07	10	SAP ERP off-host
00:04:08	08	150	SAP ERP off-host

Table 10 lists details for disk group, logical volume and file system layout of the SAP Solution Manager server, the SAP ERP server and SAP ERP off-host server. All three servers have the same layout.

**Table 10. Storage Configuration Details for SAP Solution Manager Server, SAP ERP Server and SAP ERP Off-host Server**

<i>Host LUN</i>	<i>Disk Group</i>	<i>Logical Volume</i>	<i>File System Mount Point</i>	<i>Usage</i>
00	appbin_vg	appbin_sapmnt_lv	/sapmnt	File system for central repository, SAP binaries and central location for moving data to another system when required
01	appbin_vg	appbin_usrsap<SID>_lv	/usr/sap/<SID>	File system for SAP binaries
02	appbin_vg	appbin_usrsap_trans_lv	/usr/sap/trans	File system for central location for moving data to another system
03	appbin_vg	appbin_oracle_lv	/oracle	File system for Oracle binaries for installation of Oracle, Oracle client, home directory for Oracle user and storing data temporarily for online data re-organization respectively
04	appl og_vg	appl ogA_lv	/oracle/<SID>/origlogA	File system for online redo logs of the database
05	appl og_vg	appmirrlogB_lv	/oracle/<SID>/mirrlogB	File system for duplex logs of the database
06	appl og_vg	appl ogB_lv	/oracle/<SID>/origlogB	File system for online redo logs of the database
07	appl og_vg	appmirrlogA_lv	/oracle/<SID>/mirrlogA	File system for duplex logs of the database
08	appalog_vg	apparch_lv	/oracle/<SID>/saparch	File system for archived logs
09	appdata_vg	appdata_sapdata1_lv	/oracle/<SID>/sapdata1	File system for SAP data in oracle database
0A	appdata_vg	appdata_sapdata2_lv	/oracle/<SID>/sapdata2	File system for SAP data in oracle database
0B	appdata_vg	appdata_sapdata3_lv	/oracle/<SID>/sapdata3	File system for SAP data in oracle database
0C	appdata_vg	appdata_sapdata4_lv	/oracle/<SID>/sapdata4	File system for SAP data in oracle database
0D	appdata_vg	appdata_oradata_lv	/oracle/<SID>/oradata	File system for Oracle data dictionary, temporary, UNDO and users tablespace data

The following sections describe in detail how to configure your storage for this solution.

### *Create Dynamic Provisioning Pools*

This procedure assumes that zoning within your Fiber Channel fabric is complete. To create Dynamic Provisioning pools on a Virtual Storage Platform using Hitachi Storage Navigator software, follow these steps:

1. Choose **Actions > Pool > Create Pools**.

The **Create Pools** window displays.

2. From the **Pool Type** drop-down menu, choose **Dynamic Provisioning**.

3. Click the **Select Pool VOLs** button.

The **Select Pool VOLs** window displays.

4. Highlight one or more pool volumes in the **Available Pool Volumes** pane and click **OK**.

The **Create Pools** window displays with **Total Selected Pool Volume** and **Total Selected Capacity** fields populated.

5. Assign a prefix for the pool name in the **Prefix** field.
6. (Optional) Assign an initial number for the pool name in the **Initial Number** field.
7. Expand the **Options** pane.
8. Assign a pool ID in the **Pool ID** field.
9. Assign a subscription limit in the **Subscription Limit** field.

This is the percentage of oversubscription for this pool that you allow in your environment.

10. Choose a value from the **User-Defined Threshold** drop-down menu and click the **Add** button

The **User Defined Threshold** value determines when a pool capacity alert is triggered.

The **Selected Pools** pane is populated.

11. Click the **Finish** button.
12. The **Create Pools** window displays.
13. Click the **Apply** button.

### *Create LDEVs within a Dynamic Provisioning Pool*

This procedure assumes that Dynamic Provisioning pool creation in your environment is complete. To create the LDEVs used by the data files within a Dynamic Provisioning pool using Hitachi Storage Navigator software, follow these steps:

1. Choose **Actions > Logical Device > Create LDEVs**.

The **Create LDEVs** window displays.

2. From the **Provisioning Type** drop-down menu, select **Dynamic Provisioning**.

3. From the **Emulation Type** drop down menu, select **OPEN-V**.
4. (Optional) Choose a menu item from the **Drive Type/RPM** drop-down menu and from the **RAID Level** drop-down menu.

These options allow you to filter the available pool volumes.

5. Click the **Select Pool** button.

The **Select Pool** window displays.

6. Highlight a pool in the **Available Pools** pane and click **OK**.

The **Create LDEVs** window displays with the **Selected Pool Name** and the **Selected Pool Capacity** fields populated.

7. Enter a capacity amount in the **LDEV Capacity** field and choose a unit of measure from the drop-down menu.
8. Enter the number of LDEVs of that size to be created in the **Number of LDEVs** field.
9. In the **LDEV Name** pane, assign a prefix in the **Prefix** field and assign an initial number in the **Initial Number** field.
10. Expand the **Options** pane.
11. Review the value in the **LDKC** field.

Modify the LDKC value if the default of **00** is not appropriate. This is most often the case if the storage will be configured with more than one LDKC.

12. Choose a value from the **CU** drop-down menu.
13. Choose a value from the **DEV** drop-down menu.
14. (Optional) Choose a value from **Interval** drop-down menu.

Leave this value at the default of **0** for sequential numbering of LDEVs. If you want a different numbering sequence, choose a different value.

15. Review the default values in the **Initial SSID** field, the **CLPR** field and **Processor Blade** field.

In most situations, use the default values. Change them only if your environment requires different values.

16. Click the **Add** button.

The **Selected LDEVs** pane is populated.

17. Click the **Finish** button.

The **Create LDEVs** window displays.

18. Click the **Apply** button.

## Create LDEVs in a RAID Group

This procedure is used to create the LDEVs used by the various SAP logs. To create one or more LDEVs in a RAID group using Hitachi Storage Navigator software, follow these steps:

1. Choose **Actions > Create LDEVs**

The **Create LDEVs** window displays.

2. From the **Provisioning Type** drop-down menu, select **Basic**.
3. From the **Emulation Type** drop down menu, select **OPEN-V**.
4. (Optional) Choose a menu item from the **Drive Type/RPM** drop-down menu and from the **RAID Level** drop-down menu.

These options allow you to filter the available parity group volumes.

5. Choose the **Select Free Spaces**

The **Available Free Spaces** window displays

6. Highlight the **Parity Group** in the **Available Free Space** window and choose **OK**
7. Enter a capacity amount in the **LDEV Capacity** field and choose a unit of measure from the drop-down menu.
8. Enter the number of LDEVs of that size to be created in the **Number of LDEVs** field.
9. In the **LDEV Name** pane, assign a prefix in the **Prefix** field and assign an initial number in the **Initial Number** field.
10. Expand the **Options** pane.
11. Review the value in the **LDKC** field.

Modify the LDKC value if the default of **00** is not appropriate. This is most often the case if the storage will be configured with more than one LDKC.

12. Choose a value from the **CU** drop-down menu.
13. Choose a value from the **DEV** drop-down menu.
14. (Optional) Choose a value from **Interval** drop-down menu.

Leave this value at the default of **0** for sequential numbering of LDEVs. If you want a different numbering sequence, choose a different value.

15. Review the default values in the **Initial SSID** field, the **CLPR** field and **Processor Blade** field.

In most situations, use the default values. Change them only if your environment requires different values.

16. Click the **Add** button.

The **Selected LDEVs** pane is populated.

17. Click the **Finish** button.

The **confirm** window for creating LDEVs displays.

18. Click the **Apply** button.

### *Create Host Groups*

To create host groups using Storage Navigator software, follow these steps:

1. Choose **Actions > Ports/Host Groups > Create Host Groups**.

The **Create Host Groups** window displays.

2. Assign a name in the **Host Group Name** field.
3. From the **Host Mode** drop-down menu, choose **00[Standard]**.
4. In the **Available Hosts** pane, highlight one or more hosts.
5. In the **Available Ports** pane, highlight one or more ports.
6. Click the **Add** button.

The **Selected Host Groups** pane is populated.

7. Click the **Finish** button.

The **Create Host Groups** window displays.

8. Click the **Apply** button.

### *Map LDEVs*

To map LDEVs using Hitachi Storage Navigator software, follow these steps:

1. Choose **Actions > Logical Device > Add LUN Paths**.

The **Add LUN Paths** window displays.

2. In the **Available LDEVs** pane, highlight one or more LDEVs.
3. Click the **Add** button.

The **Selected LDEVs** pane is populated.

4. Click **Next**.

The **Add LUN Paths** window displays.

5. In the **Available Host Groups** pane, highlight one or more host groups.
6. Click the **Add** button.

The **Selected Host Groups** pane is populated.

7. Click **Next**.

The **Add LUN Paths** window displays.

8. Click **Finish**.

The **Add LUN Paths** window displays.

9. Click the **Apply** button.

### *Install and Configure Hitachi Dynamic Link Manager Advanced Software*

To install Hitachi Dynamic Link Manager Advanced software and to create LVM objects and file systems on the disks on the ERP, ERP off-host and Solutions Manager servers, follow these steps:

1. Execute the following command on the server on which you want to install Hitachi Dynamic Link Manager Advanced software:

```
./installhdm
```

When the installation is complete, Hitachi Dynamic Link Manager Advanced software displays a message indicating that the software was successfully installed.

Hitachi Dynamic Link Manager Advanced software names your disk devices using the following format:

```
sddl m<di sk- devi ce>
```

**<di sk- devi ce>** is a combination of letters from a to z identifying your disk device.

2. On each server, using LVM, create a physical volume on each disk device using the following syntax:

```
pvcreate /dev/sddl m<di sk- devi ce>
```

3. On each server, using LVM, create volume groups using the following syntax:

```
vgcreate -s 64 <vol ume group name> <physi cal vol ume name or names>
```

Table 10 lists the volume groups needed for this solution.

4. On each server, create logical volumes, using the following syntax:

```
lvcreate -l <si ze of logi cal vol ume> -n <vol ume vol ume name> <vol ume group name>
```

Table 10 show the logical volumes and respective volume groups needed for this solution.

5. On each server, create a file system for each logical volume using the following syntax:

```
mke2fs -t ext2 /dev/<vol ume group name>/<logi cal vol ume name>
```

6. Mount each file system using the following syntax:

```
mount -t ext2 -o async /dev/<vol ume group name>/<logi cal vol ume name> /<mount poi nt>
```

Table 10 lists the file systems and mount points needed for this solution.

## Install and Configure SAP software

Using your existing or new Solution Manager instance, deploy the SAP ERP software for both the host and the off-host server. Install SAP Solution Manager and SAP ERP software on dedicated servers. The SAP GUI software is installed on SAP clients.

It is important to verify that the newly installed and configured hardware and software are operating properly before you make your deployment live. The verification process involves logging in to each server and executing a few transactions. For more information, see SAP Notes, which are available to licensed customers from SAP's [web site](#).

## Configure ShadowImage Heterogeneous Replication for Off-host Processing

Configure Hitachi ShadowImage Heterogeneous Replication software to replicate the current data from the SAP ERP server to the SAP ERP off-host server. Configuring ShadowImage Heterogeneous Replication software for this solution involves the following high-level steps:

1. Install Hitachi Command Control Interface software
2. Configure command devices.
3. Configure Replication using CCI.

### *Install Hitachi Command Control Interface Software*

To install Hitachi Command Control Interface software on the SAP ERP server and the SAP ERP off-host server, follow these steps:

1. Insert the installation media.
2. Navigate to the root directory:  

```
# cd /
```
3. Copy all files from the installation media using the following command:  

```
# cpio -i dmuf < /mnt/cdrom/LINUX/HORCM
```
4. Execute the HORCM installation command:  

```
# /HORCM/horcminstall.sh
```

### *Configure Command Devices*

A command device is a dedicated logical volume on the storage system that functions as the interface to the storage system from the host. The command device accepts commands that are executed on the storage system. Configure the command devices on the storage system following these steps:

1. Create an LDEV in the Dynamic Provisioning pool created for SAP ERP server as described in the "Create LDEVs within a Dynamic Provisioning pool" section and associate it to a host group of the host connection using Hitachi Storage Navigator software.

This solution uses 1GB LDEVs for the command device.

2. Convert an LDEV to a command device in Storage Navigator software by following these steps:
  - a. Choose **Actions > Ports/Host Groups**.
  - b. Expand the port (for example Port CL3-A) and choose the host group to which the LDEV for command device was mapped.
  - c. In the right pane, choose the **LUNs** and select the LDEV to be converted to command device.
  - d. Click the **Edit Command Device** button at the right bottom of the screen.

The **Edit Command Devices** dialog box displays.
  - e. In the **Edit Command Devices** dialog box, select the **enable** radio button.
  - f. Click the **Finish** button.
  - g. Click the **Apply** button.

Repeat these steps to create another LDEV for ERP off-host server, then map the LDEV to the host group and convert it to a command device for all the paths of SAP ERP off-host server so that CCI can use it to configure replication between them.

### *Configure Replication Using CCI*

CCI has two components, one residing on the storage system and another residing on the server. The CCI components residing on the storage system are command devices and ShadowImage Heterogeneous Replication volumes (P-VOLs and S-VOLS). The components residing on the servers are Hitachi Open Remote Copy Manager, also known as HORCM, configuration definition files (for example, `horcm1.conf`) and CCI commands. Although the ShadowImage Heterogeneous Replication software residing in the Hitachi Virtual Storage Platform system maintains the replication of data between the P-VOLs and the S-VOLs, it is the CCI software that allows you to manage, monitor and control the ShadowImage replication process.

The HORCM operational environment operates as a daemon process on the host server. When HORCM is activated, it refers to the configuration definition files. The HORCM instance communicates with the storage sub-system and remote servers. Two HORCM instances are required for ShadowImage Heterogeneous Replication to be operational; one manages the P-VOLs, while the other manages the S-VOLs. The HORCM configuration file defines the communication path and the logical units to be controlled. Each HORCM instance has its own HORCM configuration file. The `horcm0.conf` and the `horcm1.conf` files used for this solution are available in Appendix B. Also, modify the `/etc/services` file to register the port name and number for each HORCM instance on each server. The entries for HORCM in the `/etc/services` file must be the same on all the servers. For example, for port name `horcm0` the service number might be `11000/udp` and for the port name `horcm1` the service number might be `11001/udp` in the `/etc/services` file on both ERP server and off-host server. Figure 3 shows the two-server, two-HORCM instance configuration used for CCI for this solution.

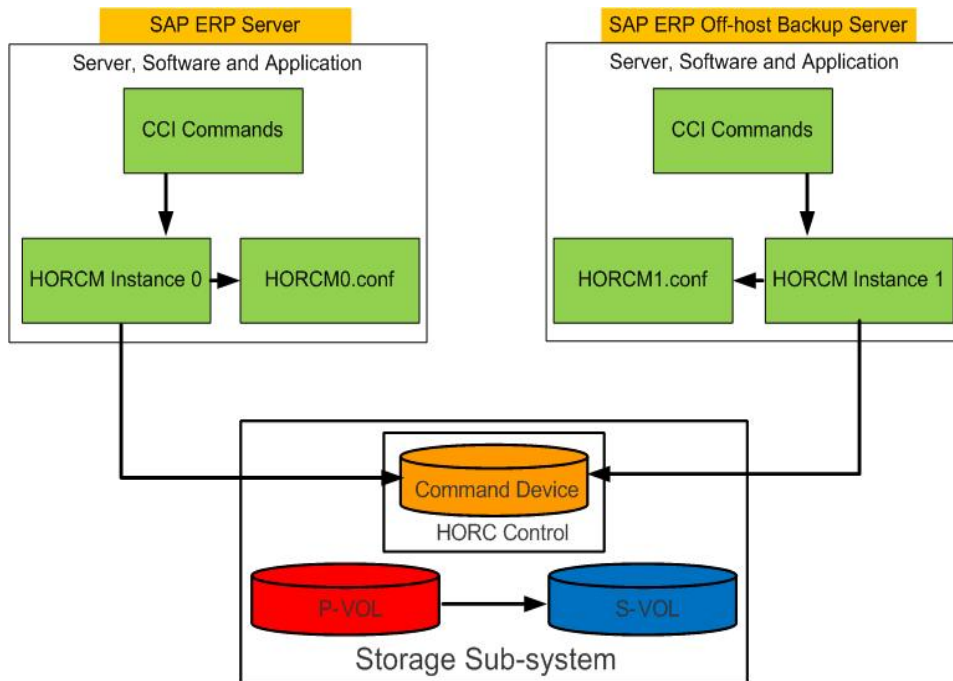

**Figure 3**

For more information about setting up the HORCM instances and HORCM configuration file, see the “Hitachi Command Control Interface (CCI) Users and Reference Guide” that accompanies the Hitachi Command Control Interface software.

CCI commands are generally executed as root user. However, CCI can be configured to allow users other than root user to execute the CCI command. In this solution, CCI commands are executed as Oracle user. Perform the pair split using the `brconnect` online split method. Ensure that the required authorizations are provided for the Oracle user to execute the CCI commands. Also ensure that the environmental variables `HORCMINST`, `HORCM_CONF` and `HORCC_MRCF` are set for the oracle user to start the HORCM instance. For more information about how to configure CCI to allow users other than root to manage replication using CCI, see Appendix C.

In the Hitachi Virtual Storage Platform family, the ShadowImage Heterogeneous Replication software consistency group function allows a user-defined group of ShadowImage Heterogeneous Replication volume pairs to be split simultaneously with a single command. This copy method creates a data-consistent, point-in-time copy of an entire system, database or any related sets of volumes. You can define multiple ShadowImage pairs as one consistency group using CCI.

After the HORCM instance is started on all the servers, you can execute CCI commands to manage, monitor, and control replication between the servers. Table11 lists CCI commands for pair operations.

**Table 11. CCI Commands for PAIR Operation**

<i>Command Name</i>	<i>Description</i>	<i>Notes</i>
<code>paircreate</code>	Creates a new pair.	Status of P-VOL and S-VOL changes from SMPL to PAIR.
<code>pairsplit</code>	Splits pairs and create a point-in-time backup in the S-VOL by stopping the update of the secondary volume. The pair relationship of the P-VOL is maintained, and the differential information is also maintained.	Status of P-VOL changes from PAIR or COPY to PSUS. Status of S-VOL changes from PAIR or COPY to SSUS.
<code>pairresync</code>	Resynchronizes pairs from PSUS or SSUS status. The direction of resynchronization is from P-VOL to S-VOL. Uses differential information to resynchronize. Only changed data needs to be copied.	Status of P-VOL changes from PSUS to PAIR. Status of S-VOL changes from SSUS to PAIR.
<code>pairresync -restore</code>	Resynchronizes pairs from PSUS or SSUS status. The direction of resynchronization is from S-VOL to P-VOL. Uses differential information to resynchronize. Only changed data needs to be copied.	Status of P-VOL changes from PSUS to PAIR. Status of S-VOL changes from SSUS to PAIR.
<code>pairsplit -S</code>	Discards the pair's differential information and deletes the pair.	Status of P-VOL changes to SMPL.
<code>pairwait</code>	Command to wait until a group enters a specified status. This command is needed to make a positive transition to the PAIR status.	N/A.
<code>pairdisplay</code>	Checks pair status and progress rate.	N/A.

## Replicate the SAP ERP System

This solution implements off-host processing for SAP ERP server using the same SID as the production SAP ERP server. This solution also implements off-host processing for SAP ERP server using a different SID than the production SAP ERP server.

For uninterrupted execution of the SAP system in the production environment, move production-like, CPU-intensive and I/O-intensive processes to a different server. To achieve this, make a consistent point-in-time copy of production server application data available on a different server using ShadowImage Heterogeneous Replication and BRBackup software. This copy of data can be used for off-host processing for functions like quality assurance testing, training, development, reporting, off-host backup and more. Figure 4 shows how the off-host processing can be achieved repeatedly using BRBackup and ShadowImage Heterogeneous Replication software.

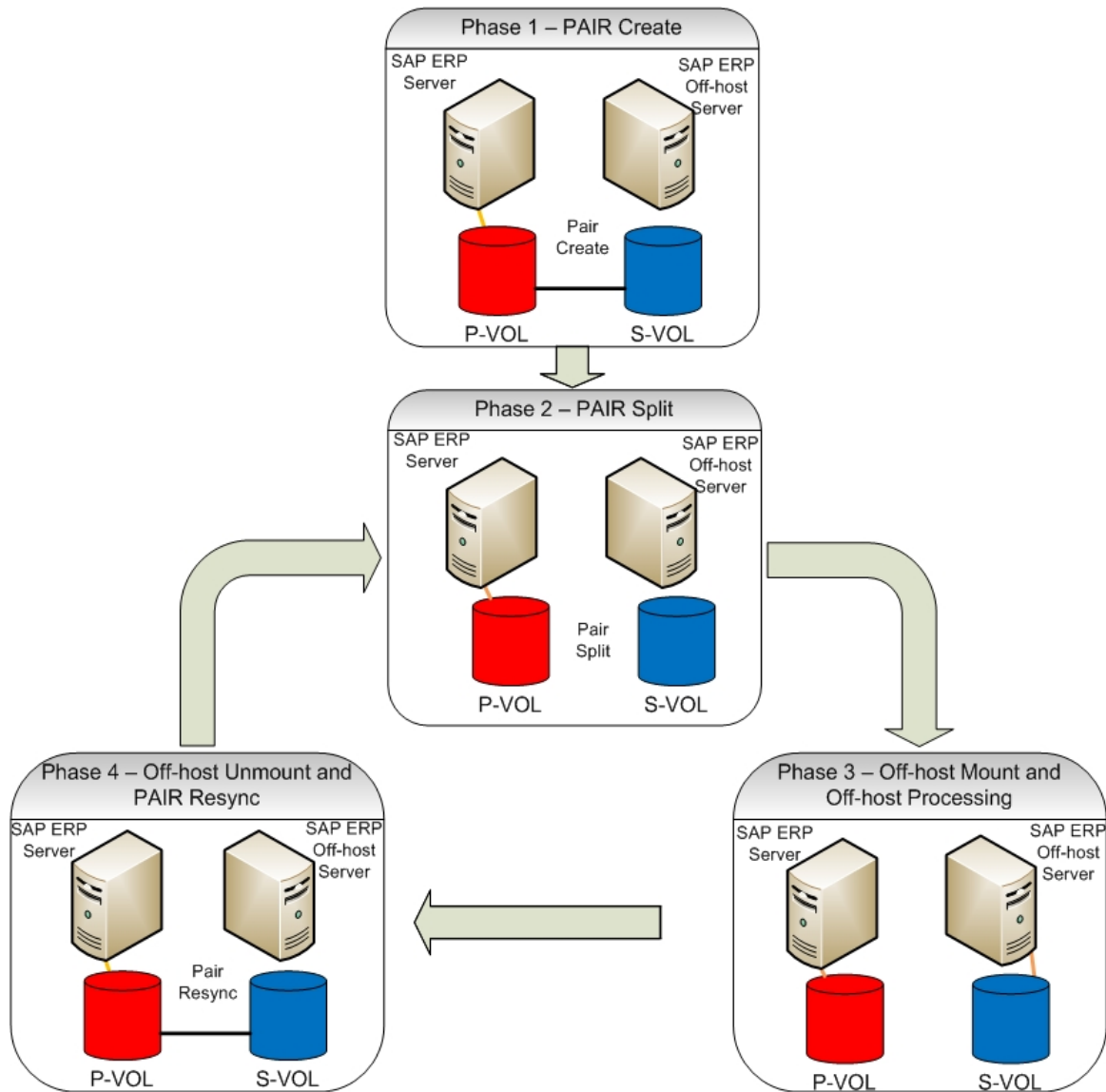

**Figure 4**

This solution tightly couples ShadowImage Heterogeneous Replication and BRBackup software. The flexibility of BRBackup allows you to initiate the backup process either from the production server or the off-host server using the `brbackup` command and a configuration file. BRBackup allows users to perform an on-line split of the mirrored volumes. You can embed the ShadowImage Heterogeneous Replication `pairsplit` and `pairresync` commands within the BRBackup configuration file. See Appendix A and Appendix B for the BRBackup configuration files.

You can initiate BRBackup from either the production server or from the off-host server. The solution described in this white paper initiates BRBackup from the off-host server. When initiating BRBackup from the off-host server, include an entry in the Oracle networking file `tnsnames.ora` on the off-host server; this allows a database connection from the off-host server to the production server. Note that if you initiate BRBackup from the production server, you must include a step to move or remove the control file created by the BRBackup process on the production server.

When you initiate the BRBackup process to perform a backup, it completes a variety of steps such as creating a copy of the control file, copying the control file to the off-host server, checking several database files, placing the database in backup mode, executing the pairsplit command, taking the database out of backup mode and overwriting old control files. Note that this solution does not use all of BRBackup's processes and as a result, you might see warnings or error messages in the BRBackup log file. However, the key steps like transitioning the database in the backup mode, executing the pairsplit command and taking the database out of backup mode are successful. Hitachi Data Systems recommends ignoring most warning or error messages in the BRBackup log files; instead review only alter database begin backup, split of mirror disks successful and alter database end backup successful messages.

Because the solution described in this white paper installs and configures SAP ERP on the off-host server, it creates ShadowImage pairs of only the volumes containing database data. Database data includes data files, log files and control files. Your use of secondary data determines whether you use the same SID or a different SID. The following sections provide information about both replication methods.

### *Replicate the SAP System with the Same SID*

The SAP ERP system deployment consists of SAP and Oracle binary files and database data. SAP ERP binary files and Oracle binary files are deployed on LUNs that are separate from LUNs containing database data. Before executing the steps to replicate an SAP system using the same SID, take a normal backup of the SAP production instances database data to recover the database in the event of failure involving data loss during the execution. It is also recommended that you install the SAP backup license on the production instance so the backup license is copied to the off-host server after the replication.

To replicate an SAP system using the same SID, follow these steps:

1. Stop SAP and the Oracle database by executing the following command as SAP user on the off-host server:  

```
# stopsap
```
2. Stop the Oracle listener by executing the following command as Oracle user on the off-host server:  

```
# lsnrctl stop
```
3. Unmount the file systems containing the off-host server's database data, logs and control files.
4. Set the environment variables for the Oracle user ora<SID> and start the HORCM instance as described in Appendix C.
5. Create ShadowImage pairs in consistency groups between LDEVs of database data of the SAP ERP server (P-VOLs ) and the corresponding LDEVs of database data of the SAP ERP off-host serves (S-VOLs) by executing the following command on the production server:

```
# paircreate -g SAP-G01 -vl -m grp -IMO
```

Monitor the pair create process by executing the `pairdisplay -g SAP-G01 -fcx` command until the P-VOLs and S-VOLs are in PAIR status.

6. Initiate BRBackup to create a consistent point-in-time split image of the SAP ERP system by executing the following command as Oracle user from the off-host server:

```
# brbackup -u system -t online_split -p initPRD.sap.onsplit
```

BRBackup places database in backup mode, splits the P-VOLs and S-VOLs using the ShadowImage pairsplit command and takes the database out of backup mode. Ensure that the SYSTEM user of database on the SAP ERP server as well as on the SAP off-host server have SYSOPER privileges granted to it.

7. Mount the file system containing database data on the off-host server.
8. On the off-host server connect to oracle database sql plus by executing the following command:

```
# SAPSI02: oraprd> sqlplus "/ as sysdba"
```

9. Start the Oracle database in the mount state by executing the following command on the off-host server:

```
SQLPLUS> startup mount pfile=' $ORACLE_HOME/dbs/initPRD.ora' ;
```

10. Recover the database by executing the following command on the off-host server:

```
SQLPLUS> recover database;
```

11. Open the database by executing the following command on the off-host server:

```
SQLPLUS> alter database open;
```

12. Shut down the database by executing the following command on the off-host server:

```
SQLPLUS> shutdown;
```

13. Start the Oracle listener by executing the following command as Oracle user on the off-host server:

```
# lsnrctl start
```

14. Start SAP and the Oracle database by issuing the following command as SAP user on the off-host server:

```
# startsap all
```

The SAP ERP system on the off-host is now available for off-host processing with same SID and with the latest data from the production SAP ERP system.

Note: When you need to refresh the data from the SAP ERP system, the LDEVs (S-VOLs) of the SAP ERP system on off-host server can be resynchronized with the data from P-VOL. This process uses the same steps listed in this procedure, except the command executed in Step 4 changes as follows:

```
# pairresync -g SAP-G01 -IMO
```

## *Replicate the SAP System with a Different SID*

The SAP ERP system deployment consists of SAP and Oracle binary files and database data. SAP ERP binary files and Oracle binary files are deployed LDEVs that are separate from LDEVs containing database data. Before executing the testing ensure to take a normal backup of the SAP production instances database data to recover the database in the event of failure involving data loss during testing.

The user name of the SAP ERP software owner and the Oracle software owner depend on the SID of the SAP ERP system. The fact that the SID is different on the SAP ERP off-host server implies that SAP ERP software owner and Oracle software user names are different than the production server. The UID and group identification numbers (GID) must be the same.

To replicate an SAP system with a different SID, follow these steps:

1. Stop SAP and the Oracle database by executing the following command as SAP user on the off-host server:  

```
# stopsap all
```
2. Stop the Oracle listener by executing the following command as Oracle user on the off-host server:  

```
# lsnrctl stop
```
3. Unmount the file systems containing database data on the off-host sever.
4. Set the environment variables as oracle ora<SID> user and start the HORCM instance as described in the Appendix C
5. Create consistent ShadowImage pairs between the LDEVs for the database data of the SAP ERP server (P-VOLs) and the corresponding LDEVs for database data of the SAP ERP off-host servers (S-VOLs) by executing the following command on the production server:  

```
# paircreate -g SAP-G01 -vl -m grp -IMO
```

Monitor the pair create process by executing the `pairdisplay -g SAP-G01 -fcx` command until the P-VOLs and S-VOLs are in PAIR status.
6. On the ERP host server connect to Oracle database `sqlplus` by executing the following command:  

```
# SAPSI02: oraprd> sqlplus "/ as sysdba"
```
7. Create an Oracle text-based server parameter file (pfile) on the production server from the binary server parameter (spfile) by executing the following command:  

```
SQLPLUS> create pfile from spfile;
```
8. Copy the `initPRD.ora` file created by the above command in the `$ORACLE_HOME/dbs/initPRD.ora` directory to the off-host server and in the off-host server copy it to the same location `$ORACLE_HOME/dbs/initPRD.ora`.
9. Exit from SQLPLUS.

10. As Oracle user, Initiate BRBackup to create a consistent point-in-time split image of the SAP ERP system by executing the following command on the off-host server:

```
# brbackup -u system -t online_split -p initDEV.sap.onsplit
```

BRBackup places database in backup mode, instructs ShadowImage Heterogeneous Replication software to split the P-VOLs and S-VOLs and takes the database out of backup mode.

Ensure that the values of environment variables SAPBACKUP, SAPDATA\_HOME and ORACLE\_SID on the SAP ERP off-host server are valid and match those environment variables on the SAP ERP server. If the directories for the environment variables need to be created, you must create them before initiating BRBackup. Also ensure that the SYSTEM user of the databases on the SAP ERP server and the SAP off-host server has been granted SYSOPER privileges.

11. On the off-host server, mount the file system containing the database data.

The mount points for these files match the production host.

12. On the off-host server, review the pfile created and copied in Step 8 to ensure that the dump destination as well as the log archive destination parameters has correct locations to reflect to the new server and mount points.

13. Connect to Oracle database `sqlplus` by executing the following command on the off-host server:

```
# SAPSI03: oradev> sqlplus "/ as sysdba"
```

14. Start the Oracle database in mount state using the pfile modified in Step 8 by executing the following command on the off-host server:

```
SQLPLUS> startup mount pfile=' $ORACLE_HOME/dbs/initPRD.ora' ;
```

The database name and database SID match the production server.

15. Recover the database by executing the following command on the off-host server:

```
SQLPLUS> recover database;
```

16. Open the database by executing the following command on the off-host server:

```
SQLPLUS> alter database open;
```

17. Shut down the database by executing the following command on the off-host server:

```
SQLPLUS> shut down;
```

18. Start the Oracle database in mount state using the pfile by executing the following command on the off-host server:

```
SQLPLUS> startup mount pfile=' $ORACLE_HOME/dbs/initPRD.ora' ;
```

19. Rename the Oracle database and Oracle database ID using the NID tool by issuing the following command on the off-host server:

```
# nid TARGET=<userid>/<password> DBNAME=DEV
```

20. Create a valid pfile for the renamed database (DEV).

An easy way to accomplish this is to copy `initPRD.ora` to `initDEV.ora` and change the parameter `db_name` to reflect the renamed database in `initDEV.ora`.

21. Open the database using the `RESETLOGS` option by executing the following command on the off-host server:

```
SQLPLUS> alter database open RESETLOGS;
```

22. Reset the password of SAPSR3 user in the database by executing the following command on the off-host server:

```
SQLPLUS> alter user SAPSR3 identified by sap;
```

23. Create a binary spfile from the text based pfile by executing the following command on the off-host server:

```
SQLPLUS> create spfile from pfile=initDEV.ora ;
```

24. Shut down the database by executing the following command on the off-host server:

```
SQLPLUS> Shut down;
```

25. Shut down the database by executing the following command on the off-host server:

```
SQLPLUS> Shut down;
```

26. Start Oracle listener by executing the following command as Oracle user on the off-host server:

```
# lsnrctl start
```

27. Start SAP and the Oracle database by executing the following command as SAP user on the off-host server:

```
# startsap all
```

28. Login as `sap*` user on the off-host SAP ERP server and install the Development system license for the SAP off-host server using the transaction `slice`.

The SAP ERP system on the off-host are now available for off-host processing with a different SID than the production SAP ERP system and with the latest data from the production SAP ERP system.

Note: When you need to refresh the data from the SAP ERP system, the LDEVs (S-VOLs) of the SAP ERP system on off-host server can be resynchronized with the data from PVOL. This process uses the same steps listed in this procedure, except the command executed in Step 5 changes as follows:

```
# pairresync -g SAP-G01 -IMO
```

This allows the SAP ERP system off-host server to obtain the changed data from the SAP ERP system on the production server. These steps can be scripted to make off-host processing into a repeatable process.

## Appendix A — Parameter Files for Replicating SAP Systems Using the Same SIDs

Hitachi Data Systems used the following files for replicating an SAP system using the same SID:

- BRBackup configuration file
- Script file for splitting P-VOLs and S-VOLs
- Oracle server parameter file on the SAP ERP server
- Oracle server parameter file on the SAP ERP off-host server

### BRBackup Configuration File

#FileName: `initPRD.sap.onsplit`

```
backup_mode = full
restore_mode = full
backup_dev_type = disk
backup_type = online_split
split_cmd = "/oracle/PRD/102_64/dbs/do_onsplit.sh"
primary_db = PRD
orig_db_home = /oracle/PRD
remote_host = SAPSI01
remote_user = oraprd
stage_copy_cmd = scp
backup_root_dir = /oracle/PRD/sapbackup
```

### Script File for Splitting P-VOLs and S-VOLs

#FileName: `do_onsplit.sh`

```
pairsplit -g SAP-G01
```

## Oracle Server Parameter File on the SAP ERP Server

#FileName: initPRD.ora

```
*. _B_TREE_BITMAP_PLANS=FALSE
*. _IN_MEMORY_UNDO=FALSE
*. _INDEX_JOIN_ENABLED=FALSE
*. _OPTIM_PEEK_USER_BINDS=FALSE
*. _OPTIMIZER_MJC_ENABLED=FALSE
*. _SORT_ELIMINATION_COST_RATIO=10
*. _TABLE_LOOKUP_PREFETCH_SIZE=0
*. background_dump_dest='/oracle/PRD/saptrace/background'
*. compatible=' 10. 2. 0'
*. control_file_record_keep_time=30
*. control_files='/oracle/PRD/origlogA/cntrl/cntrlPRD.dbf', '/oracle/PRD/origlogB/cntrl/cntrlPRD.dbf', '/oracle/PRD/sapdata1/cntrl/cntrlPRD.dbf'
*. core_dump_dest='/oracle/PRD/saptrace/background'
*. db_block_size=8192
*. db_cache_size=9133306675
*. db_files=254
*. db_name=' PRD'
*. dml_locks=4000
*. event=' 10191 trace name context forever, level 1'
*. FILESYSTEMI0_OPTIONS=' setall'
*. job_queue_processes=1
*. log_archive_dest='/oracle/PRD/saparch/PRDarch'
*. log_buffer=1048576
*. log_checkpoint_interval=0
*. log_checkpoints_to_alert=true
*. open_cursors=800
*. parallel_execution_message_size=16384
*. pga_aggregate_target=12177742233
*. processes=80
*. query_rewrite_enabled=' false'
```

```
*. recycl ebi n=' off'  
*. remote_l ogi n_passwordfi l e=' excl usi ve'  
*. remote_os_authent=true  
*. repl i cati on_dependency_tracki ng=fal se  
*. sessi ons=96  
*. sga_max_si ze=18266613350  
*. shared_pool _reserved_si ze=913330667  
*. shared_pool _si ze=9133306675  
*. sort_area_retai ned_si ze=0  
*. sort_area_si ze=2097152  
*. star_transformati on_enabl ed=' true'  
*. undo_management=' AUTO'  
*. undo_retenti on=43200  
*. undo_tabl espace=' PSAPUNDO'  
*. user_dump_dest=' /oracl e/PRD/saptrace/usertrace'
```

## Oracle Server Parameter File on the SAP ERP Off-host Server

#Fi l eName: i ni tPRD. ora

```
*. _B_TREE_BITMAP_PLANS=FALSE  
*. _I N_MEMORY_UNDO=FALSE  
*. _I NDEX_JOIN_ENABLED=FALSE  
*. _OPTI M_PEEK_USER_BINDS=FALSE  
*. _OPTI MI ZER_MJC_ENABLED=FALSE  
*. _SORT_EL I MI NATI ON_COST_RATI O=10  
*. _TABLE_LOOKUP_PREFETCH_SI ZE=0  
*. background_dump_dest=' /oracl e/PRD/saptrace/background'  
*. compati bl e=' 10. 2. 0'  
*. control_file_record_keep_ti me=30  
*. control_fi l es=' /oracl e/PRD/ori gl ogA/cntrl /cntrl PRD. dbf' , ' /oracl e/PRD/ori gl ogB/cntrl /cntrl PRD. dbf' , ' /oracl e/PRD/sapdata1/cntrl /cntrl PRD. dbf'  
*. core_dump_dest=' /oracl e/PRD/saptrace/background'  
*. db_bl ock_si ze=8192
```

\*. db\_cache\_size=9133306675  
\*. db\_files=254  
\*. db\_name=' PRD'  
\*. dml\_locks=4000  
\*. event=' 10191 trace name context forever, level 1'  
\*. FILESYSTEMI0\_OPTIONS=' setall '  
\*. job\_queue\_processes=1  
\*. log\_archive\_dest=' /oracl e/PRD/saparch/PRDarch'  
\*. log\_buffer=1048576  
\*. log\_checkpoint\_interval =0  
\*. log\_checkpoints\_to\_alert=true  
\*. open\_cursors=800  
\*. parallel\_execution\_message\_size=16384  
\*. pga\_aggregate\_target=12177742233  
\*. processes=80  
\*. query\_rewrite\_enabled=' false'  
\*. recyclebin=' off'  
\*. remote\_login\_passwordfile=' exclusive'  
\*. remote\_os\_authent=true  
\*. replication\_dependency\_tracking=false  
\*. sessions=96  
\*. sga\_max\_size=18266613350  
\*. shared\_pool\_reserved\_size=913330667  
\*. shared\_pool\_size=9133306675  
\*. sort\_area\_retained\_size=0  
\*. sort\_area\_size=2097152  
\*. star\_transformation\_enabled=' true'  
\*. undo\_management=' AUTO'  
\*. undo\_retention=43200  
\*. undo\_tablespace=' PSAPUNDO'  
\*. user\_dump\_dest=' /oracl e/PRD/saptrace/usertrace'

## Appendix B — Parameter Files for Replicating SAP Systems Using Different SIDs

Hitachi Data Systems used the following files for replicating an SAP system using different SIDs:

- BRBackup configuration file
- Script file for splitting P-VOLs and S-VOLs
- Oracle server parameter file on the SAP ERP server
- Oracle server parameter file on the SAP ERP off-host server

### BRBackup Configuration File

```
#FileName: initDEV.sap.onsplit
```

```
backup_mode = full
```

```
restore_mode = full
```

```
backup_dev_type = disk
```

```
backup_type = online_split
```

```
split_cmd = "/oracle/DEV/102_64/dbs/do_onsplit.sh"
```

```
primary_db = PRD
```

```
orig_db_home = /oracle/PRD
```

```
remote_host = SAPSI01
```

```
remote_user = oraprd
```

```
stage_copy_cmd = scp
```

```
backup_root_dir = /oracle/DEV/sapbackup
```

### Script File for Splitting P-VOLs and S-VOLs

```
#FileName: do_onsplit.sh
```

```
pairsplit -g SAP-G01
```

## Oracle Server Parameter File on the SAP ERP Server

#FileName: initPRD.ora

```
*. _B_TREE_BITMAP_PLANS=FALSE
*. _IN_MEMORY_UNDO=FALSE
*. _INDEX_JOIN_ENABLED=FALSE
*. _OPTIM_PEEK_USER_BINDS=FALSE
*. _OPTIMIZER_MJC_ENABLED=FALSE
*. _SORT_ELIMINATION_COST_RATIO=10
*. _TABLE_LOOKUP_PREFETCH_SIZE=0
*. background_dump_dest='/oracle/PRD/saptrace/background'
*. compatible=' 10. 2. 0'
*. control_file_record_keep_time=30
*. control_files='/oracle/PRD/origlogA/cntrl/cntrl PRD. dbf', '/oracle/PRD/origlogB/cntrl/cntrl PRD. dbf', '/oracle/PRD/sapdata1/cntrl/cntrl PRD. dbf'
*. core_dump_dest='/oracle/PRD/saptrace/background'
*. db_block_size=8192
*. db_cache_size=9133306675
*. db_files=254
*. db_name=' PRD'
*. dml_locks=4000
*. event=' 10191 trace name context forever, level 1'
*. FILESYSTEMI0_OPTIONS=' setall'
*. job_queue_processes=1
*. log_archive_dest='/oracle/PRD/saparch/PRDarch'
*. log_buffer=1048576
*. log_checkpoint_interval=0
*. log_checkpoints_to_alert=true
*. open_cursors=800
*. parallel_execution_message_size=16384
*. pga_aggregate_target=12177742233
*. processes=80
*. query_rewrite_enabled=' false'
```

```

*. recyclebin=' off'
*. remote_login_passwordfile=' exclusive'
*. remote_os_authent=true
*. replication_dependency_tracking=false
*. sessions=96
*. sga_max_size=18266613350
*. shared_pool_reserved_size=913330667
*. shared_pool_size=9133306675
*. sort_area_retained_size=0
*. sort_area_size=2097152
*. star_transformation_enabled=' true'
*. undo_management=' AUTO'
*. undo_retention=43200
*. undo_tablespace=' PSAPUNDO'
*. user_dump_dest=' /oracl e/PRD/saptrace/usertrace'

```

## Oracle Server Parameter File on the SAP ERP Off-host Server

The oracle profile file initDEV.ora used at Step 18 during replicating the SAP system with a different SID is as follows:

#FileName: i n i tDEV. ora

```

*. _B_TREE_BITMAP_PLANS=FALSE
*. _IN_MEMORY_UNDO=FALSE
*. _INDEX_JOIN_ENABLED=FALSE
*. _OPTIM_PEEK_USER_BINDS=FALSE
*. _OPTIMIZER_MJC_ENABLED=FALSE
*. _SORT_ELIMINATION_COST_RATIO=10
*. _TABLE_LOOKUP_PREFETCH_SIZE=0
*. background_dump_dest=' /oracl e/PRD/saptrace/background'
*. compatible=' 10. 2. 0'
*. control_file_record_keep_time=30
*. control_files=' /oracl e/PRD/ori gl ogA/cntrl /cntrl PRD. dbf' , ' /oracl e/PRD/ori gl ogB/cntrl /cntrl PRD. dbf' , ' /oracl e/PRD/sapdata1/cntrl /cntrl PRD. dbf'
*. core_dump_dest=' /oracl e/PRD/saptrace/background'
*. db_block_size=8192

```

\*. db\_cache\_size=9133306675  
\*. db\_files=254  
\*. db\_name=' DEV'  
\*. dml\_locks=4000  
\*. event=' 10191 trace name context forever, level 1'  
\*. FILESYSTEMI0\_OPTIONS=' setall '  
\*. job\_queue\_processes=1  
\*. log\_archive\_dest=' /oracle/PRD/saparch/PRDarch'  
\*. log\_buffer=1048576  
\*. log\_checkpoint\_interval=0  
\*. log\_checkpoints\_to\_alert=true  
\*. open\_cursors=800  
\*. parallel\_execution\_message\_size=16384  
\*. pga\_aggregate\_target=12177742233  
\*. processes=80  
\*. query\_rewrite\_enabled=' false'  
\*. recyclebin=' off'  
\*. remote\_login\_passwordfile=' exclusive'  
\*. remote\_os\_authent=true  
\*. replication\_dependency\_tracking=false  
\*. sessions=96  
\*. sga\_max\_size=18266613350  
\*. shared\_pool\_reserved\_size=913330667  
\*. shared\_pool\_size=9133306675  
\*. sort\_area\_retained\_size=0  
\*. sort\_area\_size=2097152  
\*. star\_transformation\_enabled=' true'  
\*. undo\_management=' AUTO'  
\*. undo\_retention=43200  
\*. undo\_tablespace=' PSAPUNDO'  
\*. user\_dump\_dest=' /oracle/PRD/saptrace/usertrace'

## Appendix C — Change CCI User from root to ora<SID> User

The CCI software is initially configured to allow only the root user (system administrator) to execute CCI commands. To start the HORCM instance as root user, ensure that the following environment variables are set.

- `HORCMINST *` (\* is HORCM instance number)
- `HORCC_MRCF 1`
- `HORCM_LOG=/HORCM/1og*`

To set the above mentioned environment variables and to start up the HORCM instance follow these steps.

1. Set the environment variable `HORCMINST`, this variable specifies the HORCM instance number to start-up.

```
export HORCMINST>(* is HORCM instance number)
```

2. Set the environment variable `HORCC_MRCF`, this variable sets the execution environment of the ShadowImage Heterogeneous Replication commands.

```
export HORCC_MRCF 1
```

3. Set the `HORCM_LOG` environment variable that specifies the command log directory.

```
export HORCM_LOG=/HORCM/1og*
```

4. Start the HORCM instance by executing the `horcmstart.sh` shell script.

```
horcmstart.sh *
```

If desired (for example, if the CCI administrator does not have root access), the system administrator can change the CCI user from root to another user name. In this solution, as described in the section “Off-Host Processing of SAP ERP System” section, the CCI commands are executed as Oracle user ora<SID>. Provide the required authorization for the oracle user ora<SID> to execute the CCI commands by following these steps:

1. Change the owner of the following CCI files from the root user to the Oracle user ora<SID>:
  - `/HORCM/etc/horcmgr`
  - All CCI commands in the `/HORCM/usr/bin` directory
  - All CCI log directories in the `/HORCM/1og*` directories

2. Change the owner of the raw device file of the **HORCM\_CMD** command in the configuration definition file from the root user to the desired user name, in this case the **ora<SID>** user.

Note that ownership of the raw device file of the command device must remain persistent across system reboots. To maintain the ownership persistent across system reboot add an entry in the **/etc/udev/rules.d/60-raw.rules** file, in the following format for the corresponding raw device file of the command device:

```
ACTION=="add", KERNEL=="raw*", OWNER=="ora<SID>", GROUP=="group", MODE=="0660"
```

3. Change the owner of the **/HORCM/.uds** directory which is created at each HORCM start-up by logging in as a user that has authorization to execute the CCI commands and issue the following command.

```
chown ora<SID> /HORCM/.uds
```

When activating the HORCM or initiating CCI command as oracle user **ora<SID>**, ensure that the environmental variables **HORCMINST**, **HORCM\_CONF**, **HORCC\_MRCF**, **HORCM\_LOG** and **HORCM\_LOGS** are set for the oracle user to start the HORCM instance. To set these environment variable follow these steps

1. Set the environment variable **HORCMINST**, this variable specifies the HORCM instance number to start-up.

```
setenv HORCMINST * (* is HORCM instance number)
```

2. Set the environment variable **HORCC\_MRCF**, this variable sets the execution environment of the ShadowImage Heterogeneous Replication commands.

```
setenv HORCM_CONF /etc/horcm*.conf
```

3. Set the environment variable **HORCC\_MRCF**, this variable sets the execution environment of the ShadowImage Heterogeneous Replication commands.

```
setenv HORCC_MRCF 1
```

4. Set the **HORCM\_LOG** and **HORCM\_LOGS** environment variable to specifies the command log directory.

```
setenv HORCM_LOG /etc/log*/curl log
```

```
setenv HORCM_LOGS /etc/log*/tmp log
```

Ensure that **HORCM\_LOG** and **HORCM\_LOGS** variables are set to appropriate values indicating the **HORCM LOG** location where the owner has permission to create log files.

5. Set the environment variable **HORCM\_EVERYCLI=1**.

```
setenv HORCM_EVERYCLI 1
```

6. Start the **HORCM** instance by executing the **horcmstart.sh** shell script.

```
horcmstart.sh *
```

## Appendix D — Hitachi ShadowImage Heterogeneous Replication Configuration Files

ShadowImage Heterogeneous Replication configuration files consist of following sections:

- **HORCM\_MON** - Contains information need to monitor a HORCM instance such as IP address, HORCM instance or service, pooling interval for monitoring paired volumes and timeout period for communication with remote server.
- **HORCM\_CMD** - Contains device path information about the command device.
- **HORCM\_LDEV** - Defines the storage sub-system device address for the paired logical volume names.
- **HORCM\_INST** - Network address of the remote server.

### ShadowImage Heterogeneous Replication Configuration Files for SAP ERP Server

#FileName: horcm0.conf

#!/\*\*\*\*\* For HORCM\_MON \*\*\*\*\*/

**HORCM\_MON**

#i p_address	servi ce	pol l (10ms)	ti meout (10ms)
172. 17. 171. 142	horcm0	1000	3000

#!/\*\*\*\*\* For HORCM\_CMD \*\*\*\*\*/

**HORCM\_CMD**

#dev\_name dev\_name dev\_name

/dev/sdq

#!/\*\*\*\*\* For HORCM\_LDEV \*\*\*\*\*/

**HORCM\_LDEV**

#dev_group	dev_name	Serial #	CU: LDEV(LDEV#)	MU#
SAP- G01	SAP_Logs_PV1	53101	03: 04	0
SAP- G01	SAP_Logs_PV2	53101	03: 05	0
SAP- G01	SAP_Logs_PV3	53101	03: 06	0
SAP- G01	SAP_Logs_PV4	53101	03: 07	0
SAP- G01	SAP_Arch_1	53101	03: 08	0
SAP- G01	SAP_Data_1	53101	03: 09	0
SAP- G01	SAP_Data_2	53101	03: 0A	0
SAP- G01	SAP_Data_3	53101	03: 0B	0

```
SAP- G01          SAP_Data_4          53101      03: 0C          0
SAP- G01          SAP_Data_5          53101      03: 0D          0
```

```
#!/***** For HORCM_INST *****/
```

```
HORCM_INST
```

```
#dev_group  ip_address      service
```

```
SAP- G01      172. 17. 171. 148  horcm1
```

## ShadowImage Heterogeneous Replication Configuration Files for SAP ERP Off-host Server

```
#FileName: horcm1.conf
```

```
#!/***** For HORCM_MON *****/
```

```
HORCM_MON
```

```
#ip_address      service  poll(10ms)  timeout(10ms)
```

```
172. 17. 171. 148      horcm1      1000      3000
```

```
#!/***** For HORCM_CMD *****/
```

```
HORCM_CMD
```

```
#dev_name          dev_name      dev_name
```

```
/dev/sdq
```

```
#!/***** For HORCM_LDEV *****/
```

```
HORCM_LDEV
```

#dev_group	dev_name	Serial #	CU: LDEV(LDEV#)	MU#
SAP- G01	SAP_Logs_PV1	53101	04: 04	0
SAP- G01	SAP_Logs_PV2	53101	04: 05	0
SAP- G01	SAP_Logs_PV3	53101	04: 06	0
SAP- G01	SAP_Logs_PV4	53101	04: 07	0
SAP- G01	SAP_Arch_1	53101	04: 08	0
SAP- G01	SAP_Data_1	53101	04: 09	0
SAP- G01	SAP_Data_2	53101	04: 0A	0
SAP- G01	SAP_Data_3	53101	04: 0B	0
SAP- G01	SAP_Data_4	53101	04: 0C	0
SAP- G01	SAP_Data_5	53101	04: 0D	0

```
#!/***** For HORCM_INST *****/
```

```
HORCM_INST
```

```
#dev_group ip_address service
```

```
SAP- G01 172. 17. 171. 142 horcm0
```

 **Hitachi Data Systems Corporation**

---

*Hitachi is a registered trademark of Hitachi, Ltd., in the United States and other countries. Hitachi Data Systems is a registered trademark and service mark of Hitachi, Ltd., in the United States and other countries. All other trademarks, service marks and company names mentioned in this document are properties of their respective owners.*

*Notice: This document is for informational purposes only, and does not set forth any warranty, expressed or implied, concerning any equipment or service offered or to be offered by Hitachi Data Systems Corporation*

© Hitachi Data Systems Corporation 2011. All Rights Reserved. AS-078-00 March 2011

**Corporate Headquarters**

750 Central Expressway,  
Santa Clara, California 95050-2627 USA  
[www.hds.com](http://www.hds.com)

**Regional Contact Information**

**Americas:** +1 408 970 1000 or [info@hds.com](mailto:info@hds.com)  
**Europe, Middle East and Africa:** +44 (0) 1753 618000 or [info.emea@hds.com](mailto:info.emea@hds.com)  
**Asia Pacific:** +852 3189 7900 or [hds.marketing.apac@hds.com](mailto:hds.marketing.apac@hds.com)