



BROCADE

HITACHI
Inspire the Next

IMPROVE PERFORMANCE WITH MAINFRAME STORAGE AND 8Gb FICON

JOHN PILGER, HITACHI DATA SYSTEMS
DAVID LYTLE, BROCADE

JUNE 8, 2011

■ Improve Performance with Mainframe Storage and 8Gb FICON

Learn how to improve your overall mainframe system throughput and I/O performance while reducing your operational costs. Experts from Hitachi Data Systems and Brocade will discuss how Hitachi Virtual Storage Platform and Brocade networking solutions can dramatically improve elapsed time of critical batch processing as well as improve online transactional system response time through faster I/O processing and the implementation of 8Gb FICON.

By attending this webcast you will learn to :

- Improve your overall mainframe storage infrastructure with a smaller storage footprint as well as reduced power and HVAC requirements.
- Achieve faster response time with the latest storage technology including faster internal processing as well as SSD and SAS disk drives.
- Understand how 8Gb switched FICON is important and can increase your mainframe performance.



- Hitachi Data Systems and Brocade partnership
- Mainframe value depends on the storage sub-system
- Hitachi Virtual Storage Platform and FICON
- Brocade DCX Director and 8Gb FICON

- Hitachi Data Systems and Brocade
 - Leaders in providing storage and storage networks for open systems and mainframe environments
 - Long standing partnership
 - Broad range of solutions for local and remote connectivity
 - Services to deliver end-to-end solutions
 - Years of experience with mainframe storage and storage connectivity



- **RAS (reliability, availability, serviceability)**
 - RAS translates into redundancy, architecture, scalability
- **Performance**
 - Time is money – e.g. Processing peaks and other SLAs
 - Transaction response time and batch throughput
 - Speed of storage network
 - Ability of storage sub-system to handle transaction load and deliver excellent response and throughput
- **Functionality**
 - Flexibility of storage network components
 - Configuration flexibility of storage array
 - Security
 - Virtualization
 - Ease of use – configuration, tuning, maintenance



- VSP provides essential IBM® compatibility and delivers Hitachi unique innovation
 - Ideal solution for mainframe storage requirements
- Delivers outstanding performance
 - 3D scalability lets you scale up for performance, scale out for capacity and scale deep to enable virtualization of external storage
 - Frontend and backend directors cache and processors handle time sensitive processing tasks
 - Multiple disk drive technologies to meet performance needs (SSD, SAS and SATA)
 - VSP processors, cache and STAR network work together to deliver outstanding performance and reliability

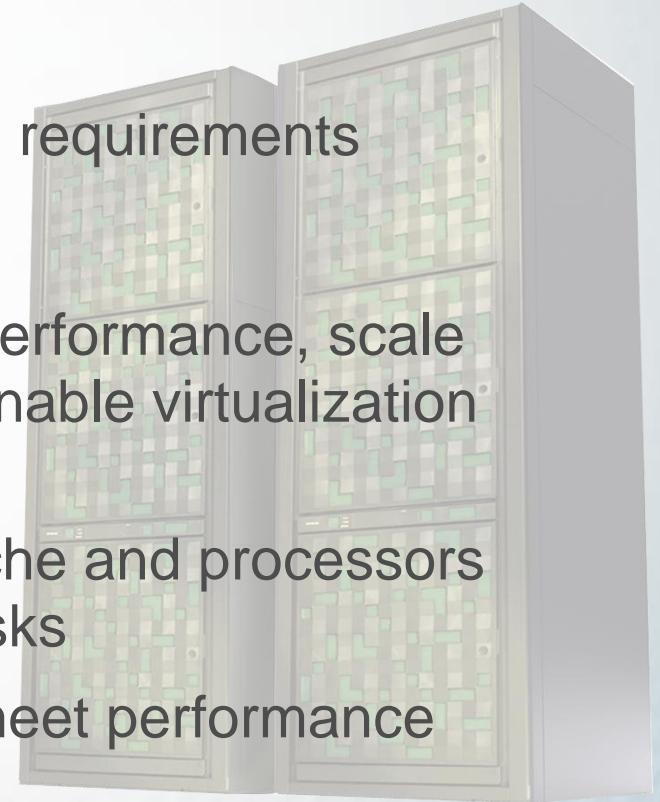

HITACHI VIRTUAL STORAGE PLATFORM RACK STRUCTURE

The maximum number of racks is 6:
2 control chassis and 16 drive chassis

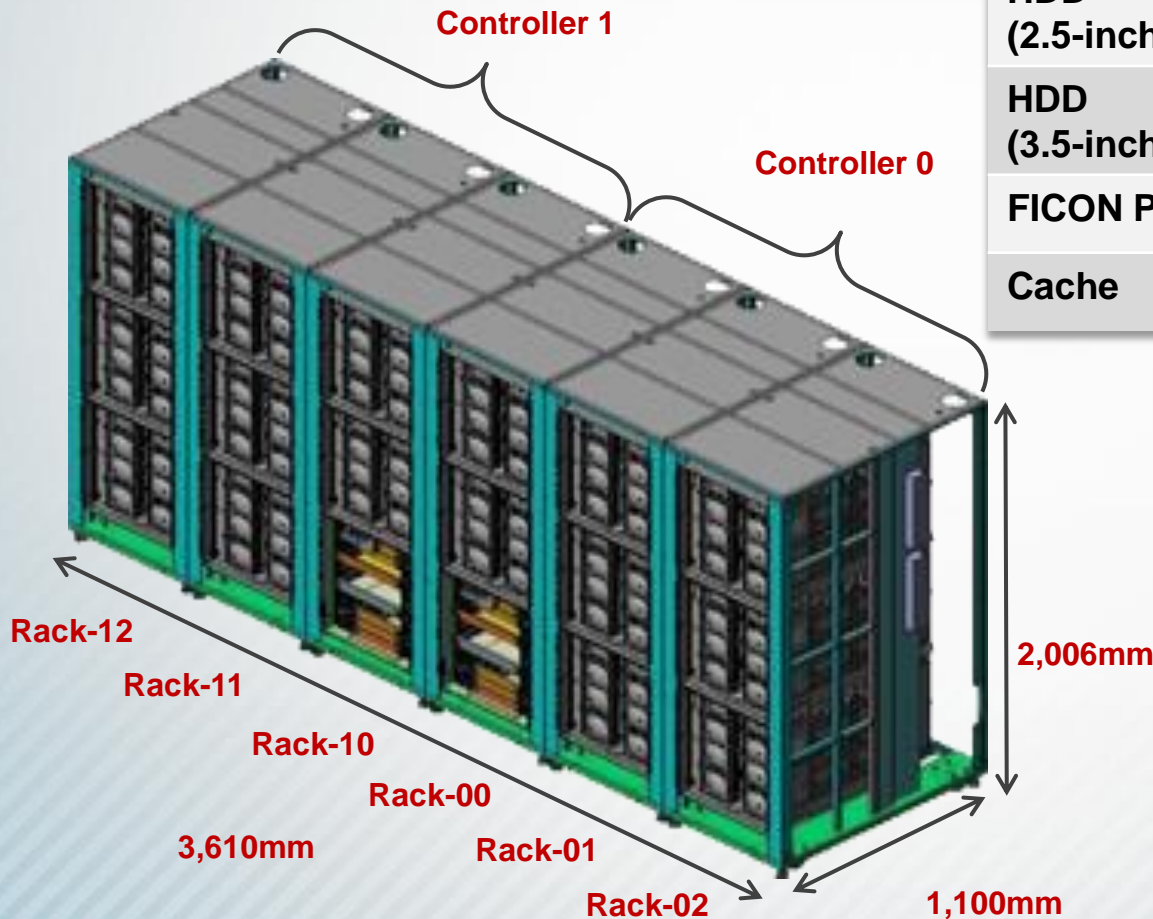

	1 CONTROL CHASSIS	2 CONTROL CHASSIS
HDD (2.5-inch)	0 - 1,024	0 - 2,048
HDD (3.5-inch)	0 - 640	0 - 1,280
FICON Ports	16 - 88*	16 - 176*
Cache	Up to 512GB	Up to 1,024GB

- **Frontend directors (FEDs)**
 - 24 FEDs provide up to 192 FICON ports (2, 4 and 8Gb) with a total bandwidth of 204.8Gb
 - FEDs include dual core processors and cache for time sensitive operations
- **Backend directors have a 6Gb SAS interface to all disk drives**
 - SSD and SAS disks provide outstanding performance and reliability for FICON environments
- **Virtual storage directors, cache and STAR Network provide outstanding performance and support for FICON**
 - Performance throughput of over 1,000,000 IOP/s



System Throughput

<i>IO Type</i>	<i># Chan</i>	<i>Block BUFNO</i>	<i>CLPR</i>	<i># Vols</i>	<i>Result IOPS</i>	<i>Response (ms)</i>
Front End						
Read	32	4KB x 1	128GB	256	1,012,709	< 0.3
Write	32	4KB x 1	128GB	256	939,996	< 0.3
Zero Locality						
Read	32	4KB x 1	64GB	2048	230,000	5.9
Write	32	4KB x 1	64GB	2048	64,000	< 1.0
Sequential					MBPS	
Read	32	27KB x 30	128GB	2048	12,100	n.a
Write	32	27KB x 30	128GB	1024	5,374	n.a.

Large German banking service provider

- **Environment**
 - 3 large multi-location Sysplex systems
 - Services over 400 banks and with 130,000,000 accounts
 - Online transaction processing
 - Batch processing – daily, weekly, monthly, annual
 - Hitachi USP V and IBM DS8000s
 - Brocade DCX Director
- **Challenge**
 - Migration of largest customer had to be completed in a 24 hr window
 - With only USP V and DS8000 process took over 40 hours
- **Solution**
 - Installed VSP systems
 - Migration completed in 20 hours



- Hitachi Virtual Storage Platform is the ideal storage subsystem for mainframe storage
- Provides essential IBM compatibility while delivering Hitachi unique capabilities
- VSP architecture designed to deliver industry leading performance
- Combination of Hitachi storage and Brocade storage networking deliver outstanding performance and reliability

BROCADE'S PARTNERSHIP WITH HDS

Brocade is the preferred infrastructure in more than 90% of Global 1000 data centers



Solutions

Customer Satisfaction

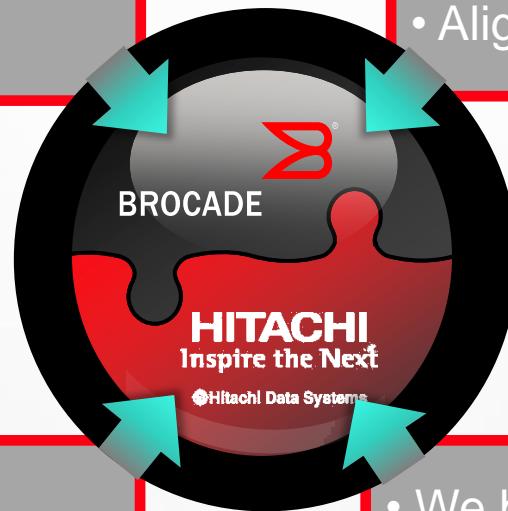

- Mainframe connectivity and storage
- Storage and infrastructure virtualization
- Business Continuity and DR

- Customer satisfaction #1 priority
- Dedicated account team of 40+
- Alignment with HDS partners

- Investment in interoperability
- Solutions testing with 3rd parties
- 2,000 HDS DCX chassis installed

- We both have global coverage
- Strong alignment with Hitachi, Ltd.
- Extensive testing and qualification

Proven Deployments

Collaboration with Hitachi, Ltd.



BROCADE



DCX is the **GOLD Standard** for Mainframe connectivity!

Brocade's DCX Family Provides Your Best Value When Deploying An I/O Infrastructure:

- Best 8Gb switched-FICON performance
- Superior port density alternatives
- World-class power efficiencies
- Significant protection of your investment
- Single-Pane-of-Glass management of FICON, FCP, IP

INCREASED DEMANDS ON FABRICS

You have just heard how the Hitachi VSP DASD scales up for performance and scales out for capacity which may mean your old I/O infrastructure might need updating!

Some Things Need To Be Replaced!



**Low Speed
and Performance Bottlenecks!**

- Your enterprise needs the highest speed switching for your control units and storage



Host/Storage is getting Faster and Faster!



BRUNO

Building Blocks for the Dynamic FICON Infrastructure

Consolidation and Performance

Brocade Network Advisor

F C I P

<p>16p Blade</p> <p>32p Blade</p> <p>48p Blade</p>	<p>Brocade DCX-4S 16-192 ports 1, 2, 4, 8, 10 Gbps FC, FICON (CEE/FCoE not used with FICON)</p>	<p>Brocade DCX 16-384 ports 1, 2, 4, 8, 10 Gbps FC, FICON (CEE/FCoE not used with FICON)</p>
----------------------------------------------------	------------------------------------------------------------------------------------------------------------------------	---------------------------------------------------------------------------------------------------------------------

<p>Brocade 5100 24, 32, 40 ports 1, 2, 4, 8 Gbps FC, FICON</p>	<p>Brocade 5300 48, 64, 80 ports 1, 2, 4, 8 Gbps FC, FICON</p>
-----------------------------------------------------------------------------------	-----------------------------------------------------------------------------------

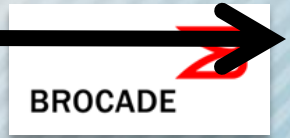
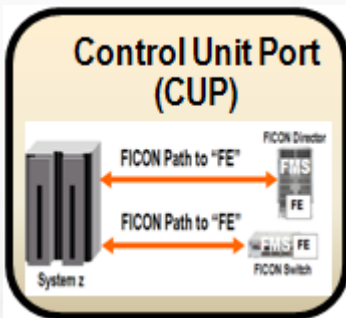

OVERVIEW OF DCX AND DCX-4S FOR FICON

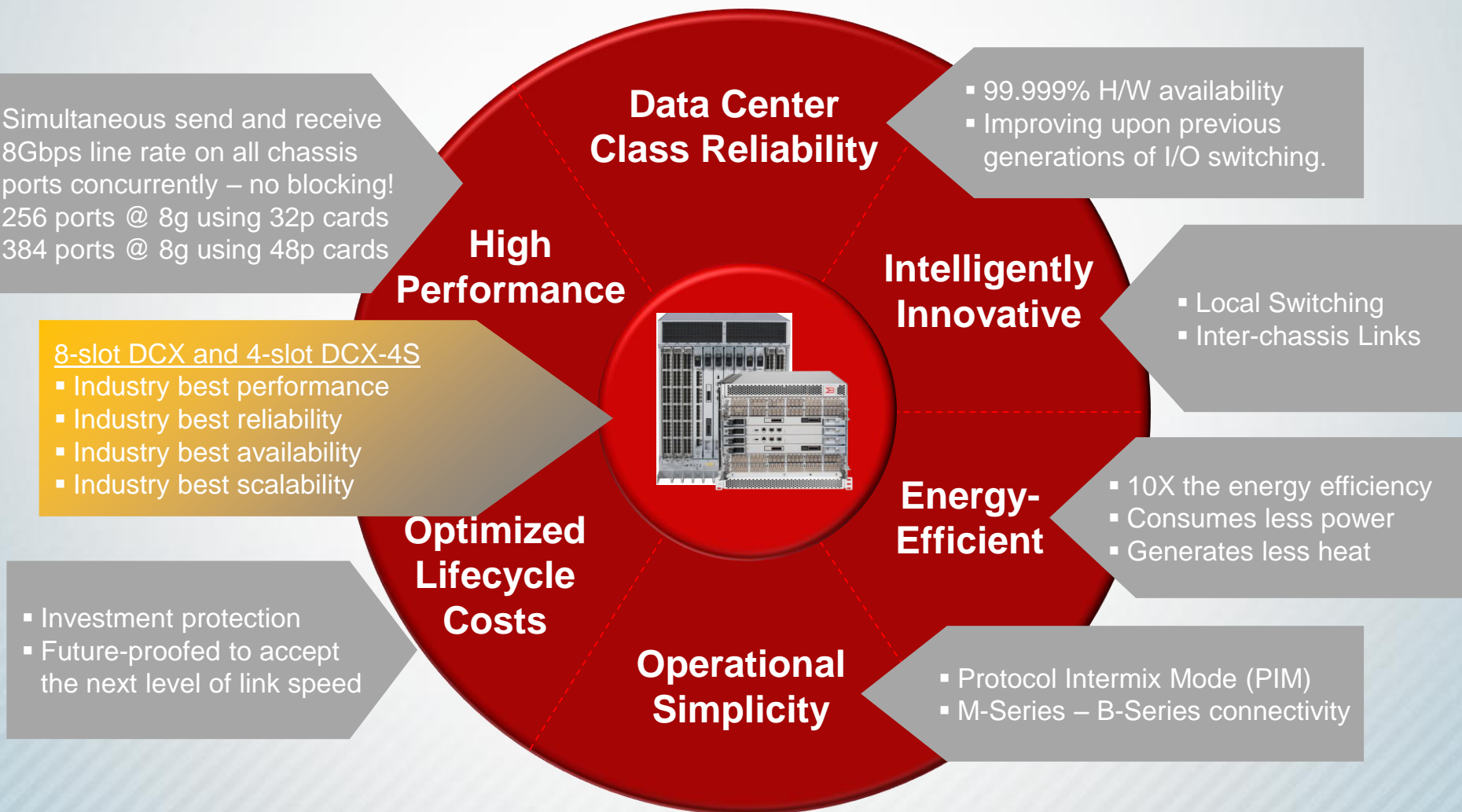

The worlds most Powerful, Effective and Efficient switched-FICON I/O Infrastructure Platforms!



WHERE 8 GBPS FC/FICON IS NEEDED NOW

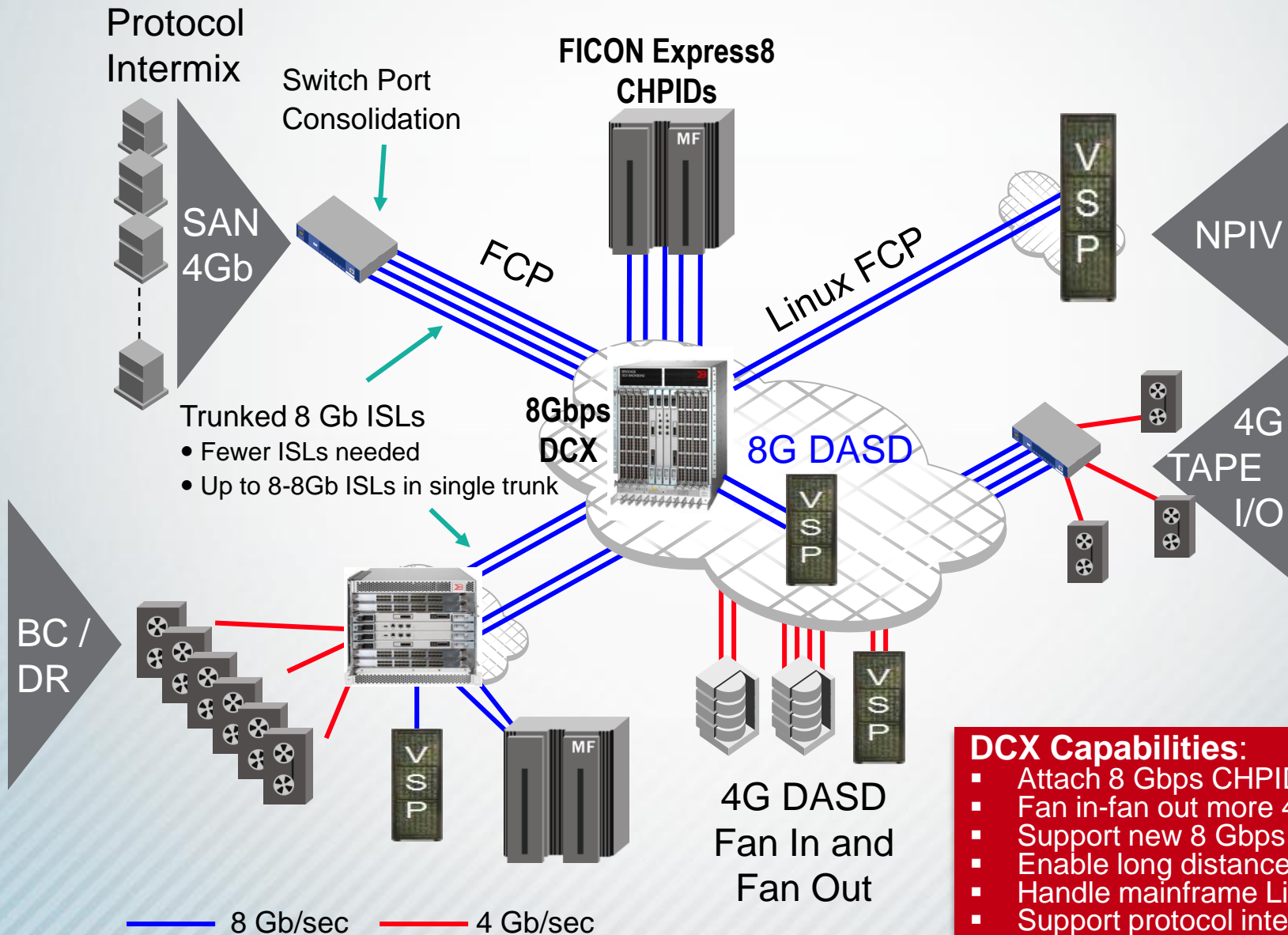

DCX Capabilities:

- Attach 8 Gbps CHPID ports
- Fan in-fan out more 4G storage
- Support new 8 Gbps DASD
- Enable long distance BC/DR
- Handle mainframe Linux growth
- Support protocol intermix

BROCADE

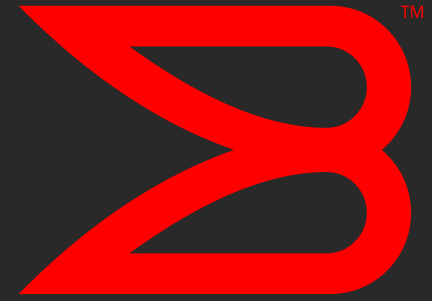

BROCADE AND HDS

DEPLOYING I/O INFRASTRUCTURE IN MAINFRAME SHOPS

FICON BASIC SWITCHED IMPLEMENTATION DEPLOYING SWITCHED-FICON INTO DAS SHOPS

Mainframe Enterprise Accounts

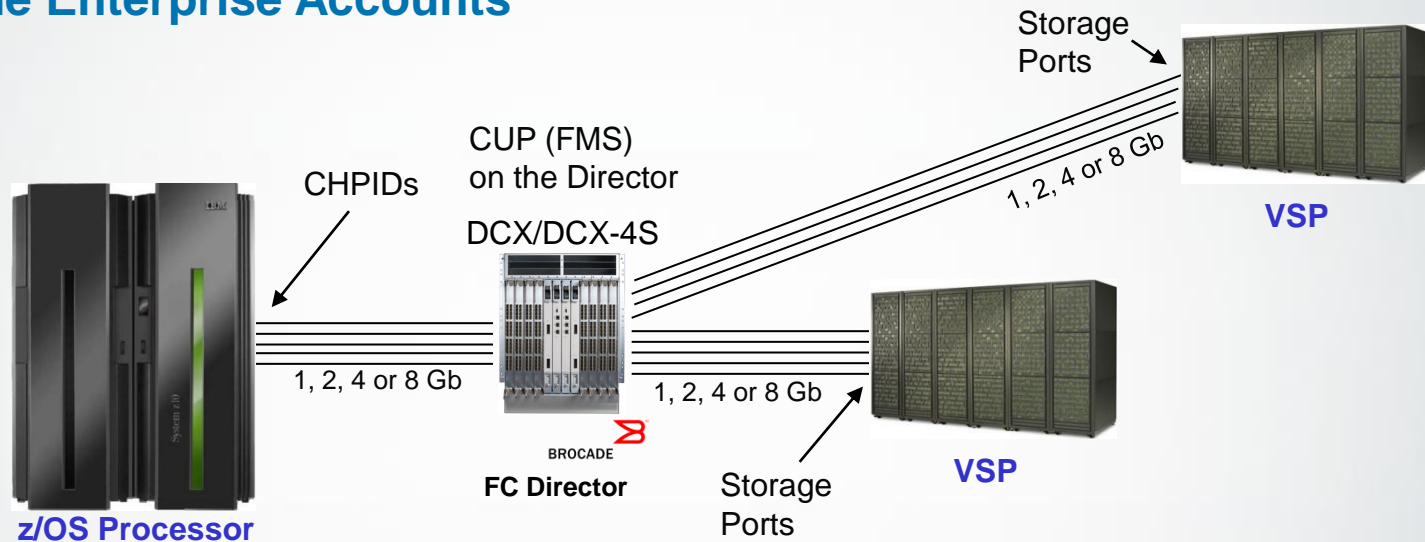

Value Proposition

- Mainframe shops that direct attach FICON storage cannot utilize all current z/OS capabilities
- DCX fully supports FICON attachment to one or more Storage Arrays via mainframe CHPIDs.
- Switched FICON supports SCALING OUT through our ability to add additional storage ports and/or arrays without the need to add additional CHPIDs.
- Switched-FICON supports SCALING UP through our ability to achieve better utilization of the storage channels as well as higher levels of connectivity through the sharing of connections.
- CUP (Control Unit Processor) on the DCX/DCX-4S provides an interface to z/OS for performance reporting and management.

BROCADE DCX CAN REPLACE YOUR OLD 2/4Gbps SWITCHED-FICON DIRECTORS

- Since 2000, many customers have deployed 2/4 Gbps M-Series, B-Series and competitive FICON fabrics
- Now it is time to Scale Up these tired, older infrastructures to meet today's requirements
- Brocade has the safest migration path for expanding and updating these older generations of mainframe I/O and storage networks
- Brocade offers greater product breadth and a complete, robust roadmap for years to come
- And, Brocade offers the best ROI and investment protection story



■ Common Brocade (McDATA) M6140 Consolidation

Average Ports

96-128

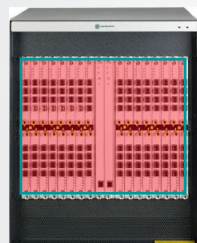

M6140

DCX

(up to 256p w/32p blades)

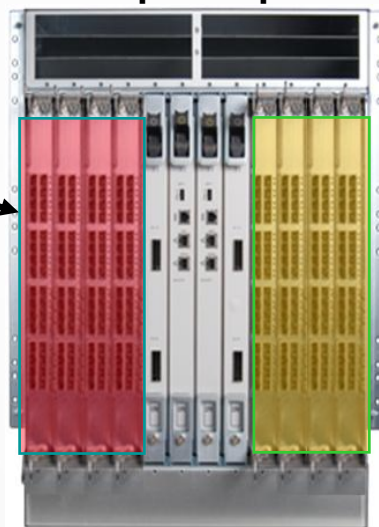

Average Ports

96-128

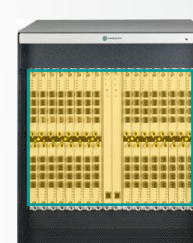

M6140

- Up to 8 logical switches per DCX or DCX-4S
 - Up to 3 logical switches per B5100 and B5300
- Up to 2 Instances of CUP per logical switch
 - Could use other logical switches for open systems traffic

FICON INTERMIXED WITH OPEN SYSTEMS PROTOCOL INTERMIX MODE (PIM)

- Optional on DCX/DCX-4S, Virtual Fabrics create isolated, independently managed domains within the same chassis frame.
- Virtual Fabrics (VF) create the strongest form of port isolation enabling easy upgrade migrations and very safe protocol intermixed mode (PIM) environments.
- Our VF, combined with VSP offers a unique opportunity to consolidate the physical I/O infrastructure while safely maintaining logically separate I/O traffic environments.

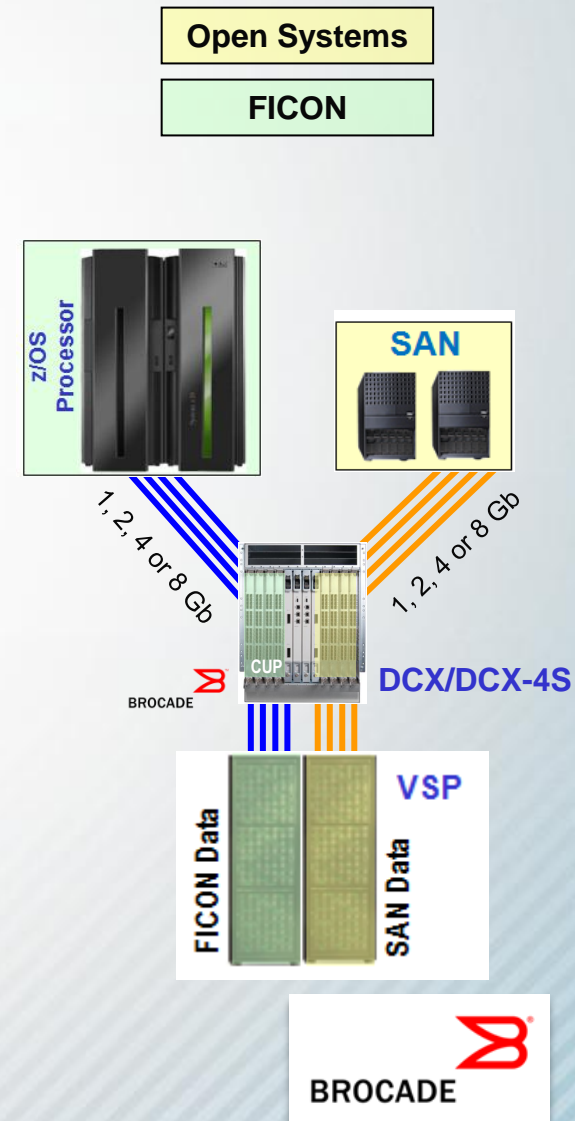



Working Together



BROCA

A WORLD CLASS PARTNERSHIP

Systems

QUESTIONS AND DISCUSSION

June

- **ESG presents: How to Buy Storage Virtualization**, June 22, 2011 at 9am PT, 12pm ET
- **Storage Service Level Management**, June 29, 2011 at 9am PT, 12pm ET

July

- **Technical Series on Hitachi Dynamic Tiering and Hitachi Dynamic Provisioning**

Please check www.hds.com/webtech for:

- Link to the recording, the presentation and Q&A (available next week)
- Schedule and registration for upcoming WebTech sessions



THANK YOU